

LI-ION TAMER GEN 3 USER MANUAL



January 2026
Doc. No. 37141_A8

Disclaimer

The contents of this document is provided on an "as is" basis. No representation or warranty (either express or implied) is made as to the completeness, accuracy or reliability of the contents of this document. The manufacturer reserves the right to change designs or specifications without obligation and without further notice. Except as otherwise provided, all warranties, express or implied, including without limitation any implied warranties of merchantability and fitness for a particular purpose are expressly excluded.

Intellectual Property and Copyright

This document includes registered and unregistered trademarks. All trademarks displayed are the trademarks of their respective owners. Your use of this document does not constitute or create a licence or any other right to use the name and/or trademark and/or label. This document is subject to copyright owned by Xtralis. You agree not to copy, communicate to the public, adapt, distribute, transfer, sell, modify or publish any contents of this document without the express prior written consent of Xtralis.

General Warning

This product must only be installed, configured and used strictly in accordance with the General Terms and Conditions, Warranty, User Manual, Third Party Licenses, and product documents available from Xtralis website (www.xtralis.com). All proper health and safety precautions must be taken during the installation, commissioning and maintenance of the product. The system should not be connected to a power source until all the components have been installed. Proper safety precautions must be taken during tests and maintenance of the products when these are still connected to the power source. Failure to do so or tampering with the electronics inside the products can result in an electric shock causing injury or death and may cause equipment damage. Xtralis is not responsible and cannot be held accountable for any liability that may arise due to improper use of the equipment and/or failure to take proper precautions. Only persons trained through an Xtralis accredited training course can install, test and maintain the system.

Cybersecurity Warning

This product must only be installed in a secure location or manner with access controls in place.

Liability

You agree to install, configure and use the products strictly in accordance with the User Manual and product documents available from Xtralis.

Xtralis is not liable to you or any other person for incidental, indirect, or consequential loss, expense or damages of any kind including without limitation, loss of business, loss of profits or loss of data arising out of your use of the products. Without limiting this general disclaimer the following specific warnings and disclaimers also apply:

Fitness for Purpose

You agree that you have been provided with a reasonable opportunity to appraise the products and have made your own independent assessment of the fitness or suitability of the products for your purpose. You acknowledge that you have not relied on any oral or written information, representation or advice given by or on behalf of Xtralis or its representatives.

Total Liability

To the fullest extent permitted by law that any limitation or exclusion cannot apply, the total liability of Xtralis in relation to the products is limited to:

- (i) in the case of services, the cost of having the services supplied again; or
- (ii) in the case of goods, the lowest cost of replacing the goods, acquiring equivalent goods or having the goods repaired.

Indemnification

You agree to fully indemnify and hold Xtralis harmless for any claim, cost, demand or damage (including legal costs on a full indemnity basis) incurred or which may be incurred arising from your use of the products.

Miscellaneous

If any provision outlined above is found to be invalid or unenforceable by a court of law, such invalidity or unenforceability will not affect the remainder which will continue in full force and effect. All rights not expressly granted are reserved.

FCC Warning

WARNING: This equipment generates, uses, and can radiate radio frequency energy and if not installed and used in accordance with the instruction manual may cause interference to radio communications. It has been tested and found to comply with the limits for class A computing devices pursuant to Subpart B of Part 15 of FCC Rules, which is designed to provide reasonable protection against such interference when devices are operated in a commercial environment. Operation of this equipment in a residential area is likely to cause interference, in which case the user will be required to correct the interference at his or her own expense.

Canadian Requirements

This digital apparatus does not exceed the Class A limits for radiation noise emissions from digital apparatus set out in the Radio Interference Regulations of the Canadian Department of Communications.

Le present appareil numerique n'emet pas de bruits radio-electriques depassant les limites applicables aux appareils numeriques de la classe A prescrites dans le Reglement sur le brouillage radioelectrique edicte par le ministere des Communications du Canada.

China RoHS Hazardous Substance Table

Component Name	Hazardous Substances					
	Lead (Pb)	Mercury (Hg)	Cadmium (Cd)	Chromium VI Compounds (Cr6+)	Polybrominated Biphenyls (PBB)	Polybrominated Diphenyl Ethers (PBDE)
Hub, PoE	X	0	0	0	0	0
Controller, Gen 3	X	0	0	0	0	0
Power Supply, 12 VDC	X	0	X	0	0	0
Power Supply, 48 VDC	X	0	X	0	0	0
This table is prepared in accordance with the provisions of SJ/T 11364.						
0: Indicates that said hazardous substance contained in all of the homogeneous materials for this part is below the limit requirement of GB/T 26572.						
X: Indicates that said hazardous substance contained in all of the homogeneous materials for this part is above the limit requirement of GB/T 26572.						

- EPUP 10 years
- All other components, not listed in the table, do not contain restricted substances above the threshold level.



This symbol on our product shows a crossed-out "wheelie-bin" as required by law regarding the Waste of Electrical and Electronic Equipment (WEEE) disposal. This indicates your responsibility to contribute in saving the environment by proper disposal of this Waste i.e. Do not dispose of this product with your other wastes. To know the right disposal mechanism please check the applicable law.

Contact Us

www.xtralis.com

Contents

1	General	5
1.1	Scope.....	5
1.2	Key Features.....	5
1.3	Certifications	5
1.4	Codes, Standards or Regulations	6
1.5	Quality Assurance.....	6
1.5.1	Manufacturer.....	6
1.5.2	Equipment Supplier	6
1.5.3	Installer	6
1.5.4	Training.....	6
1.6	Documentation	6
2	System Specifications and Operation	7
2.1	System Architecture	7
2.1.1	Small Systems	7
2.1.2	Medium Systems	7
2.1.3	Large Systems.....	8
2.2	Power Consumption	8
2.3	Environmental Specifications	9
2.4	Sensor Specifications	9
2.4.1	Design Level	9
2.4.2	Reference Sensor Function/ Lockout State.....	10
2.4.3	Detection Method and Output.....	10
2.5	Sensor Daisy-Chain	11
2.5.1	Hub and Terminator Specifications.....	12
2.5.2	Daisy-Chain Architecture.....	13
2.5.3	Hub and Sensor LED Function	14
2.5.4	Hub Push Button Function.....	15
2.6	Control and Networking Architecture	16
2.6.1	Controller Specifications	16
2.6.2	Ethernet Switch Specifications	16
2.6.3	PoE Switch Specifications	17
2.6.4	Relay Module Specifications.....	18
2.7	Li-ion Tamer Part Numbers	20
3	Application	21
3.1	Sensor Placement	21
3.1.1	Monitoring Sensor Placement.....	21
3.1.2	Reference Sensor Placement.....	22
3.1.3	System Layout Example	22
3.2	Signal Integration	22
3.2.1	Relay Output Integration.....	22
3.2.2	Modbus Output Integration	24
4	Installation, Operation and Maintenance	26
4.1	System Installation	26
4.1.1	Sensor and Hub Installation.....	26
4.1.2	Ethernet Switch Installation	28
4.1.3	Controller Installation	29
4.1.4	Relay Module Installation.....	30
4.1.5	Power Supply Installation	32
4.1.6	Cable Length Limitations	33
4.2	System Configuration (Software)	34
4.2.1	Configuration Preparation.....	34

4.2.2	Login and Initial System Setup	34
4.2.3	Configure Sensors	37
4.2.4	Dashboard	43
4.2.5	Users Tab	46
4.2.6	Settings Tab.....	47
4.2.7	Download Tab.....	51
4.3	System Commissioning	53
4.3.1	Bump Test Procedure.....	54
4.3.2	Error Handling and Diagnostics	55
4.4	Maintenance and Service	59
4.4.1	Maintenance Tests	59
4.4.2	Spare Parts	59
4.4.3	System Decommissioning	59
5	Frequently Asked Questions.....	60

1 General

1.1 Scope

This document provides specification details of the Li-ion Tamer[®] GEN 3 system and is intended to aid users in installation, operation, and maintenance.



Notes!

- This device detects the venting of electrolyte vapours from lithium-ion batteries. It does not prevent fires or thermal runaway. This device is not a stand-alone safety device and should be incorporated into a proper safety system. If device responds, there is a risk of battery fault which could lead to thermal runaway. To avoid injury, leave area immediately.
- The Li-ion Tamer system must be powered OFF any time the battery system is being commissioned, tested, maintained, etc. Li-ion Tamer is intended for operating battery systems, so alarms may be activated if exposed to cross-sensitive gases from the environment surrounding the battery system.

1.2 Key Features

- Early warning of lithium-ion battery failures
- Enable thermal runaway prevention with proper mitigation actions
- Single cell failure detection without electrical or mechanical contact of cells
- Extended product lifetime
- Calibration-free product
- Highly reliable output signal
- Compatible with all lithium-ion battery form factors and chemistries
- Easy installation
- Independent and redundant perspective on battery health
- Auto diagnostic capabilities
- Reduction/removal of false positive signals
- Communication protocols including relays and Modbus serial

1.3 Certifications

The GEN 3 system has been designed and tested to meet the following certifications:

- FM 6540 Approved for Battery Electrolyte Solvent Vapours (ex. DEC, DMC, EMC)
- ETL listed to UL 61010 and CSA 22.2 NO. 61010 for product safety
- EN 61326-1:2013 for EU Directive (2014/30/EU)
- RoHS 3 EU 2015/863, WEEE, and REACH compliant
- UKCA
- FCC

1.4 Codes, Standards or Regulations

The GEN 3 system is to be installed in battery systems according to the following codes and regulations:

- Any national or international standards or fire codes that require detection of battery electrolyte solvent vapour for early intervention detection (ex. NFPA 75 & 76, FM 5-33).
- Any national or international standards or fire codes that require off-gas monitoring detection
- Local codes and standards

1.5 Quality Assurance

1.5.1 Manufacturer

The manufacturer has an ISO 9001:2015 registered quality system and is committed to achieving the following objectives:

- Development of innovative process and product solutions.
- On-time delivery of products and services to our customers.
- Provide for the safety and empowerment of our team members.
- Continual improvement of operations and our quality system.

1.5.2 Equipment Supplier

- The equipment supplier shall be authorized trained by the manufacturer to calculate/design, install, test and maintain the Li-ion Tamer system.
- The equipment supplier shall be able to produce a certificate of training from the manufacturer.

1.5.3 Installer

- The installation and configuration of the Li-ion Tamer GEN 3 system shall be performed by trained suppliers or commissioning parties.
- The equipment installer shall be authorized and trained by the manufacturer and shall have the ability to design a system based on code requirements.
- The installer shall be capable of providing calculations, design, and testing documents upon request.

1.5.4 Training

- The manufacturer or agent of the manufacturer shall train all personnel involved in the supply, installation, commissioning, operation and maintenance of the GEN 3 system. Contact Xtralis representative to arrange training sessions.

1.6 Documentation

The following documentation shall be supplied by the manufacturer:

- Product technical datasheets, user manual, and site layout drawings for sensor placement, when applicable.
- The manufacturer's user manual shall be supplied to all installing and purchasing parties.
- The manufacturer's user manual shall be supplied to all suppliers and commissioning parties.

2 System Specifications and Operation

2.1 System Architecture

The Li-ion Tamer GEN 3 system is easily scalable to provide flexible solutions for a wide range of battery systems and applications. The system architecture primarily depends on the quantity of sensors that are deployed in each unique Li-ion Tamer system.

2.1.1 Small Systems

Small systems are those that require a maximum of 12 Sensors and a single Hub per Li-ion Tamer system. Note that this architecture is only valid for the Hub, Direct Power (LT-ACC-HUB-PWR).

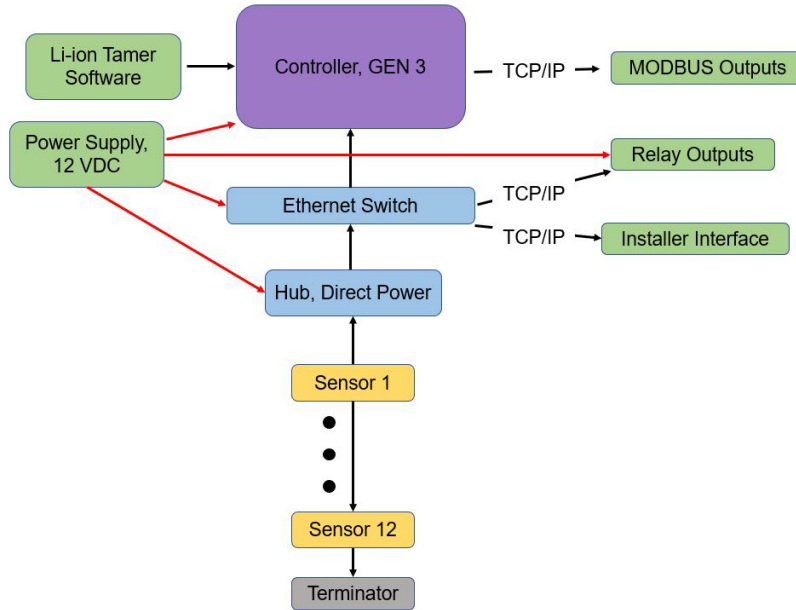

2.1.2 Medium Systems

Medium systems are those that require multiple hubs and a single ethernet switch, either standard or PoE. These systems require an ethernet switch that aggregates the Hubs and connects them to the Controller.

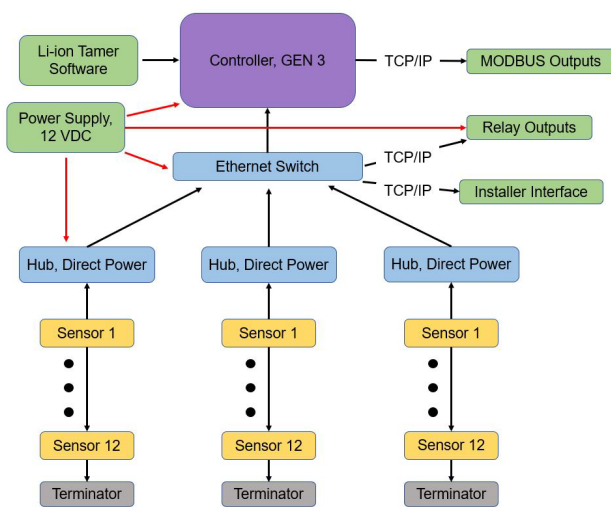

Figure 1: Option A: Hub, Direct Power

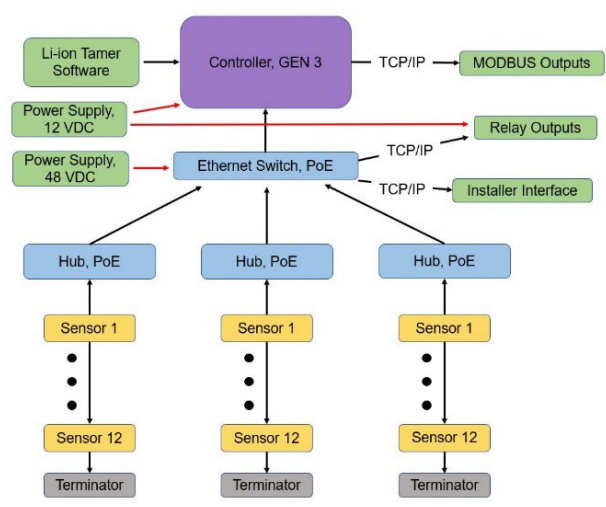
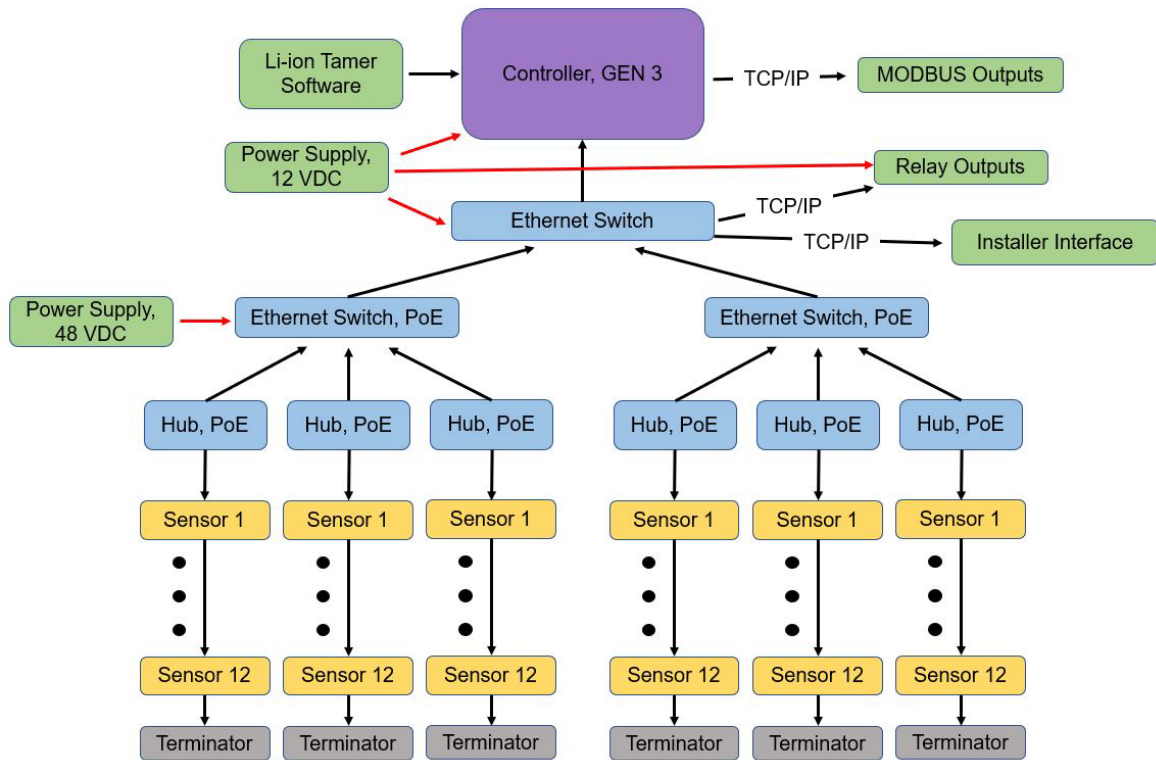

Figure 2: Option B: Hub, PoE

2.1.3 Large Systems

Large systems are those that require multiple Hubs and two tiers of ethernet switches, either standard or PoE. These systems require multiple ethernet switches that aggregate the Hubs and connect them to the Controller.



2.2 Power Consumption

The power consumption requirements are detailed below for the different components that require external power supply.

Maximum Power Consumption Specifications		
Item	Part Number	Specification
Controller, GEN 3	LT-CTR-SML	3 A (36 W @ 12 VDC)
Ethernet Switch, PoE, 4 ports	LT-ACC-POE-4	1.6 A (76 W @ 48 VDC) 0.3 A baseline plus 0.32 A per PoE port
Ethernet Switch, PoE, 24 ports	LT-ACC-POE-24	2.22 A (244.3 W @ 110 VAC) 0.28 A baseline plus 0.08 A per PoE port
Ethernet Switch, 5 ports	LT-ACC-ETS-5	0.29 A (3.5 W @ 12 – 48 VDC)
Ethernet Switch, 8 ports	LT-ACC-ETS-8	0.4 A (4.8 W @ 12 – 48 VDC)
Ethernet Switch, 16 ports	LT-ACC-ETS-16	1 A (12 W @ 12 – 48 VDC)
Hub, Direct Power (fully populated)	LT-ACC-HUB-PWR	0.5 A (6.0 W @ 12 VDC)
Ethernet Relay Module, 16 ports	LT-ACC-ERO-16	0.44 A (5.3 W @ 9 – 30 VDC)

The DIN-rail mountable power supplies, with specifications detailed below, are provided by Xtralis for ease of installation. The 12 VDC power supply is typically used to power all components listed above, except for the PoE switches.

Power Supply Specifications			
Model		Power Supply, 12 VDC (LT-ACC-PWR-12)	Power Supply, 48 VDC (LT-ACC-PWR-48)
Output	DC Voltage	12 V	48 V
	Rated Current	10 A	2.5 A
Input	Voltage Range	90 ~ 264 VAC	
	AC Current	2.25 A/ 115 VAC; 1.3 A/ 230 VAC	
	Frequency Range	47 ~ 63 Hz	
Environment	Operating Temperature	-20 to +70°C	
	Operating Humidity	20 to 95% RH (non-condensing)	
	Storage Temp., Humidity	-40 to +85°C, 10 to 95% RH	

For further specifications and dimensioned drawings, refer to the Mean Well Datasheet (<https://www.meanwellusa.com/upload/pdf/NDR-120/NDR-120-spec.pdf>).



Note!

The Li-ion Tamer GEN 3 system does not qualify as fire detection or fire alarm system equipment; therefore, power supply equipment regulations (ex. EN 54-4) do not apply.

2.3 Environmental Specifications

The environmental operating conditions are detailed below. Operating outside of the specified ranges may lead to decreased performance and part damage.

Environmental Specifications		
Component	System	Sensor
Operating Temperature	0 to 40°C	-10 to +50°C
Operating Humidity	0 to 90% RH (non-condensing)	20 to 90% RH (non-condensing)
Storage Temp., Humidity	5 to 30°C, 10 to 80% RH	
Max. Temperature Change	8.6°C/ min	



Note!

The Li-ion Tamer sensor is designed for operation in nominal air (21% O₂). The sensor should not be operated in depleted oxygen atmospheres, however, performance has been demonstrated down to 2% O₂.

2.4 Sensor Specifications

2.4.1 Design Level

The sensor hardware includes the Monitoring Sensors (LT-SEN-M3) and Reference Sensors (LT-SEN-R3). Monitoring Sensors are indicated by black endplates and are mounted near lithium-ion batteries to detect the battery electrolyte solvent vapours. Reference Sensors are indicated by blue endplates and are mounted near external contaminant entry points to prevent false-positive alarms.



Figure 3: Monitoring Sensor (LT-SEN-M3)

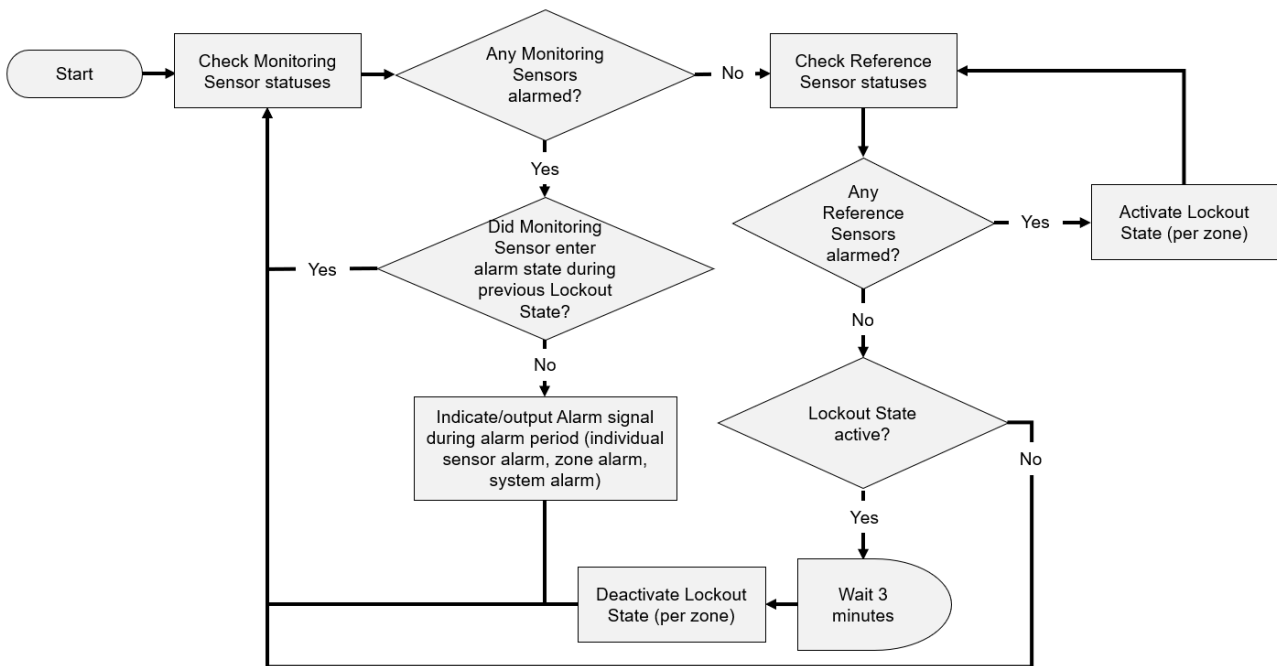

Figure 4: Reference Sensor (LT-SEN-R3)

2.4.2 Reference Sensor Function/ Lockout State

As noted in the previous section, the Li-ion Tamer GEN 3 system utilizes Reference Sensors as a method of false-positive alarm prevention. It does so by activating an internal Lockout State if a Reference Sensor detects gas prior to a Monitoring Sensor, which would be an indication of contaminant gas entry.

Users do not need to take any action if the Lockout State has been activated, as it is only a means of false-positive prevention and does not indicate a true alarm or error condition. The flow diagram below defines how the Lockout State is implemented and is only provided for reference.



2.4.3 Detection Method and Output

Each sensor includes an off-gas sensor that is acutely sensitive to battery electrolyte solvent vapours (off-gassing compounds).

The detection method for the off-gas sensor is as follows:

1. Raw sensor signal is gathered as a continuous function.
2. Li-ion Tamer Event Detection Algorithm processes the signal with a discrete algorithm function indicating event detection.

Gas Detection Specifications	
Target gases	Lithium-ion battery electrolyte solvent vapours, ex. DEC, DMC, EMC (FM 6540 Approved)
Minimum Detection Threshold	10 ppm/sec
Minimum Response Time	5 seconds
Fault Detection	Single cell failure

They are also equipped with temperature and relative humidity sensors for increased environmental monitoring.

Temperature Measurement Specifications	
Measurement Range	-40 to 125°C (-40 to 257°F)
Measurement Accuracy	± 0.4°C from 5 to 60°C (41 to 140°F)
Humidity Measurement Specifications	
Measurement Range	0 to 100% RH (non-condensing)
Measurement Accuracy	± 2.0% RH from 20 to 80% RH



Note!

Extended exposure of sensor to flammable gases is not known to negatively affect its performance.

2.5 Sensor Daisy-Chain

The sensor daisy-chain is a sub-section of the overall system architecture, as shown below, and is comprised of a Hub, Sensors, and a Terminator.

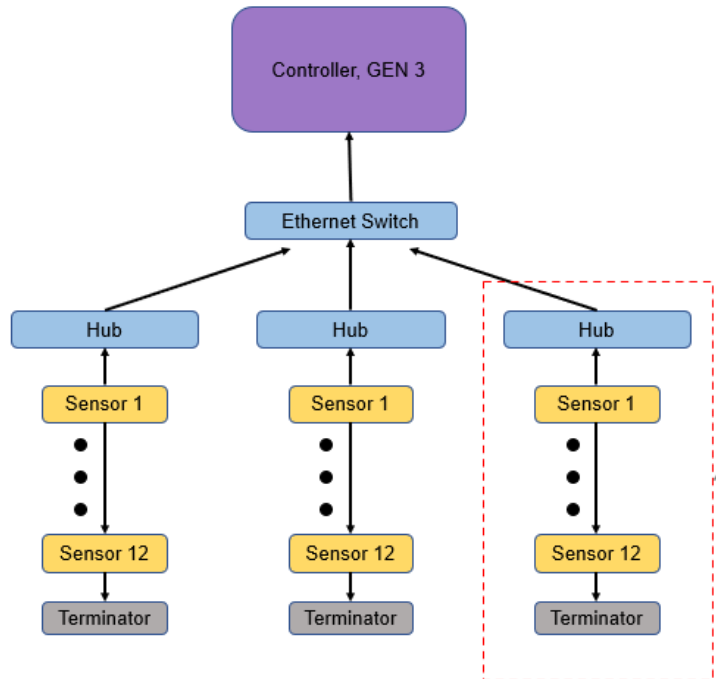

2.5.1 Hub and Terminator Specifications

The Hub originates the daisy-chain connection of the sensors for the purposes of power distribution and CANbus communications. There are two types of hubs, and their use depends on the overall system size and architecture (see *Section 2.1*). Each Hub can accept a maximum of 12 Sensors, regardless of the type of sensor.

**Note!**

Only one type of Hub may be used per controller. It is not advised to use both the LT-ACC-HUB-PWR and LT-ACC-HUB-POE on the same controller.

The Hub, Direct Power (LT-ACC-HUB-PWR) is primarily used for small systems since it can be powered with the same 12 VDC power supply as the controllers.



The Hub, PoE (LT-ACC-HUB-POE) is primarily used for larger systems since multiple hubs can be powered using an Ethernet Switch, PoE. Using this type of hubs requires a PoE Ethernet switch, which requires a 48 VDC power supply; therefore, its use is only recommended in situations where it may be difficult to provide 12 VDC power to each hub.



Each Hub comes with a Terminator(s), which is required for operation of the sensor daisy-chain, detailed in the following section. The Terminator is a simple RJ45 plug that terminates the end of the CANbus communication at the last sensor in the chain.

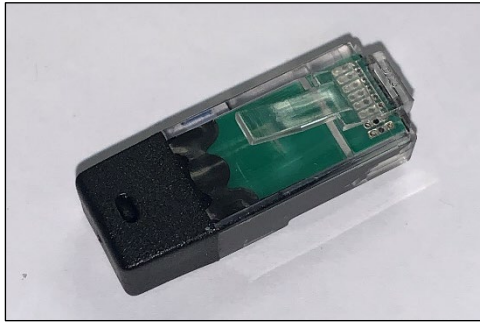

2.5.2 Daisy-Chain Architecture

The daisy-chain CANbus communication architecture involving the sensors, hubs, and terminators simplifies the installation by reducing cable material and routing. The type of Hub being used will affect how power is supplied to the daisy-chain and how many chains can be connected. Make note of the important nomenclature, shown in **bold**, as it will be continued throughout the manual.

The simplified wiring diagram below details how a typical daisy-chain using a Hub, Direct Power would be setup. A **sensor chain** connects to the **Chain A port** with a Terminator connected to the last sensor. Power is provided to the hub via a 12 VDC terminal block located on the same side of the hub as the sensor chain input. The **hub output port** is located on hub's opposite end and connects to either an Ethernet Switch or Controller.

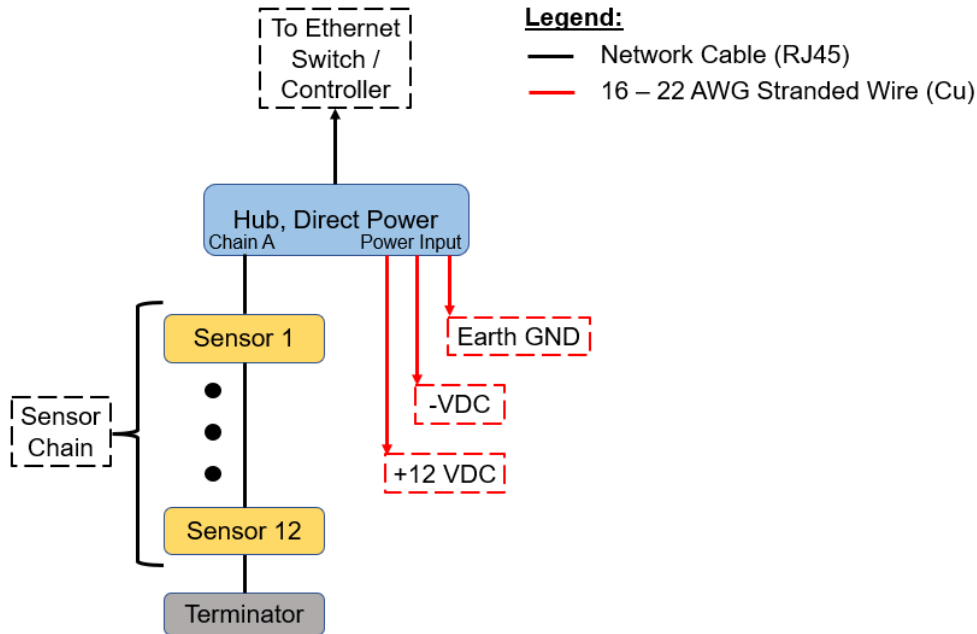

The simplified wiring diagrams below detail how typical daisy-chains using a Hub, PoE would be setup. Sensor chains can be connected to either the **Chain A port**, **Chain B port**, or both with a Terminator connected to the last sensor of each chain. Sensor quantities can be split in any way between Chain A and Chain B but cannot exceed 12 total sensors per hub. The **hub output port** is located on hub's opposite end and connects to an Ethernet Switch, PoE, which also provides power to the hub.

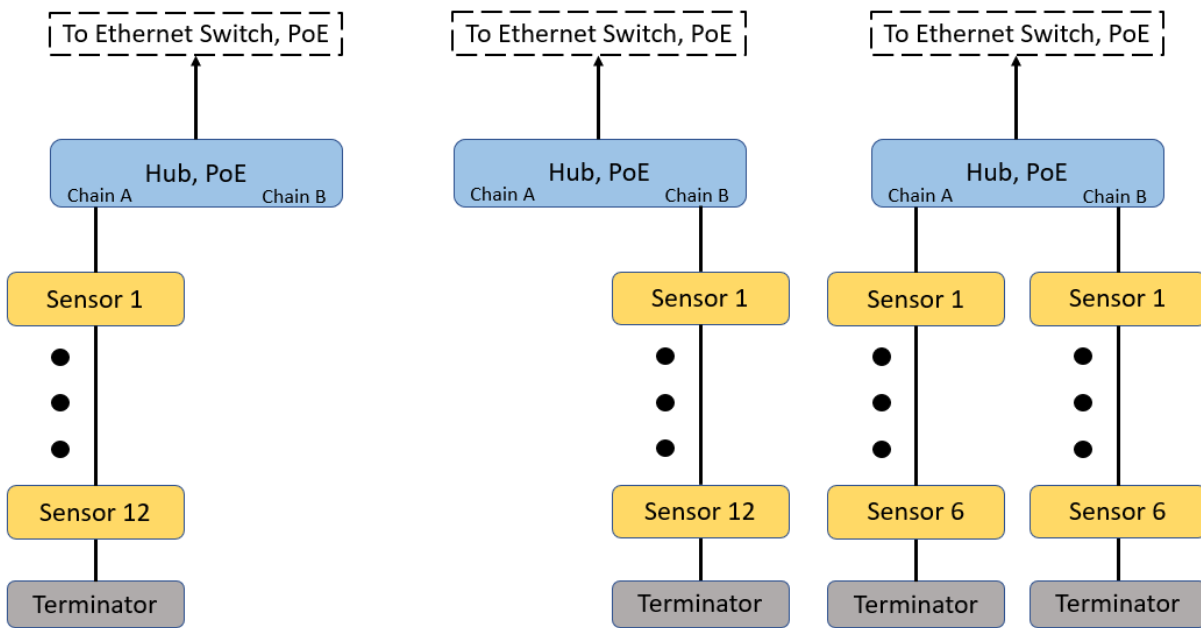

2.5.3 Hub and Sensor LED Function

The sensors and hubs utilize on-board LEDs to indicate the normal operating states and a variety of error states that may occur.

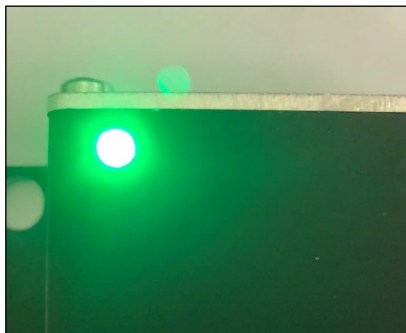

The LEDs communicate the status of the sensor or hub using different colours, shown above, and discernible ON/OFF “states”. The table below lists the definitions of each state.

State	Definition
Dark	LED is OFF continuously
Solid	LED is ON continuously
Slow Flash	1.0 sec ON, 1.0 sec OFF, repeating
Fast Flash	0.25 sec ON, 0.25 sec OFF, repeating
Blip	0.2 sec ON, 1.8 sec OFF, repeating
Pulse	0.5 sec ON, 0.5 sec OFF, repeating for a number of counts

The table below details the different LED indicators for the sensor.

LED Indicator	Sensor Status
Green Blip	Normal operation
Red Fast Flash	Gas detected by sensor
Green Pulse	Sensor Position – Monitoring Sensor only
Blue Pulse	Sensor Position – Reference Sensor only

LED Indicator	Sensor Status
Blue Slow Flash	Sensor powering on or setting ID, not communicating for first 10 seconds
Yellow Fast Flash	Error communicating with hub
Yellow Solid	Application code crashed, running in bootloader mode
Dark *	Loss of power or device failure

* Sensor LEDs will be OFF for several seconds after power is applied as they boot.

The table below details the different LED indicators for the hub.

LED Indicator	Hub Status
Green Blip	Normal operation
Red Slow Flash	Gas detected by sensor on daisy-chain
Blue Slow Flash	Hub powering on, not communicating for first 10 seconds
Blue Fast Flash	Sensors indicating their IDs and warming up, Hub connecting to controller
Yellow Slow Flash	Terminator missing from daisy-chain
Yellow Fast Flash	Error communicating with sensor or controller
Yellow Solid	Application code crashed, running in bootloader mode
Dark	Loss of power or device failure

2.5.4 Hub Push Button Function

The hubs are equipped with a push button that resides next to their output port. The push button will not typically be used during installation and commissioning but can be helpful for troubleshooting.

Push Button Action	Function
Press 1 time	Start and stop display of sensor position on the chain on the sensor LEDs
Press 3 times	Reconnect sensors to hub – sensors and hub will re-enter warmup phase

2.6 Control and Networking Architecture

2.6.1 Controller Specifications

The Li-ion Tamer GEN 3 Controller is a Linux-based industrial computer that aggregates and processes sensor signals, communicates sensor status, and records a detailed history of time-stamped data from the sensors for post-event diagnosis.



The Controller, GEN 3 (LT-CTR-SML) is cross-functional for all system sizes, with a maximum of 100 sensors (see section 2.1). It has the below general specifications:

- Dimensions: 115 (L) x 82 (W) x 34 (H) [mm]
- Input power range: 12 VDC (see section 2.2 for power consumption)
- Maximum of 100 sensors per controller
- Maximum of 10 hubs per controller (recommended)
- System outputs Modbus TCP/IP over Ethernet with optional relay module(s)

Each Controller has two RJ45 ethernet ports, labelled Network 1 and Network 2, as shown below. Network 1 is for the internal detection network only and is where the hubs, ethernet switches, and relay modules connect to the controller. Network 2 is for external Modbus TCP/IP signal communication and may be set to a static IP address for interfacing with customer systems.

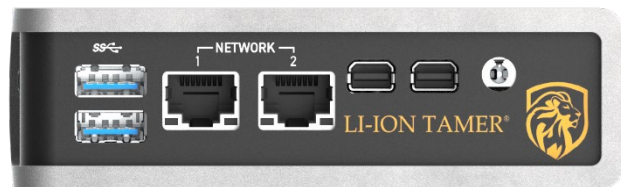

2.6.2 Ethernet Switch Specifications

All systems require either a standard Ethernet switch or a PoE Ethernet switch (see section 2.6.3). Xtralis provides three sizes of standard Ethernet switches based on the number of ports they have. The table below lists the different options and their basic specifications. All standard Ethernet switches are unmanaged models.

Part Number	Number of Ports (RJ45 10/100)	Input Power Range
LT-ACC-ETS-5	5	12 – 48 VDC (see section 2.2 for power consumption)
LT-ACC-ETS-8	8	
LT-ACC-ETS-16	16	

Dimensions of each model are detailed below in mm/ [inches].

Note that Xtralis has multiple suppliers for the ethernet switches, so exact dimensions may vary. For additional drawings and model files, please contact an Xtralis representative.

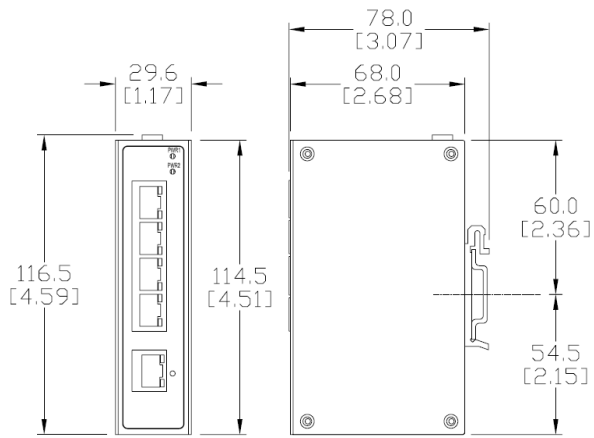

Figure 5: Ethernet Switch, 5 port (LT-ACC-ETS-5)

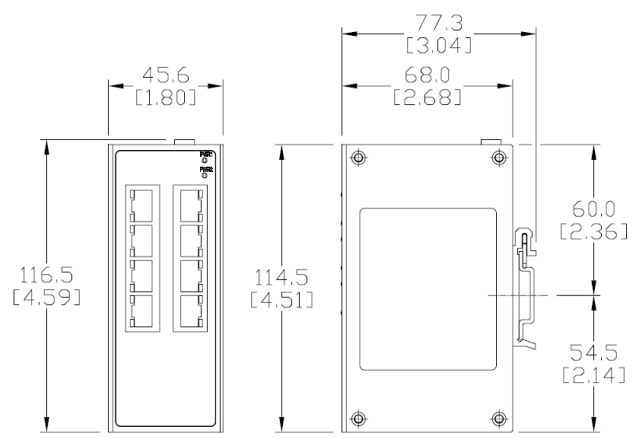

Figure 6: Ethernet Switch, 8 port (LT-ACC-ETS-8)

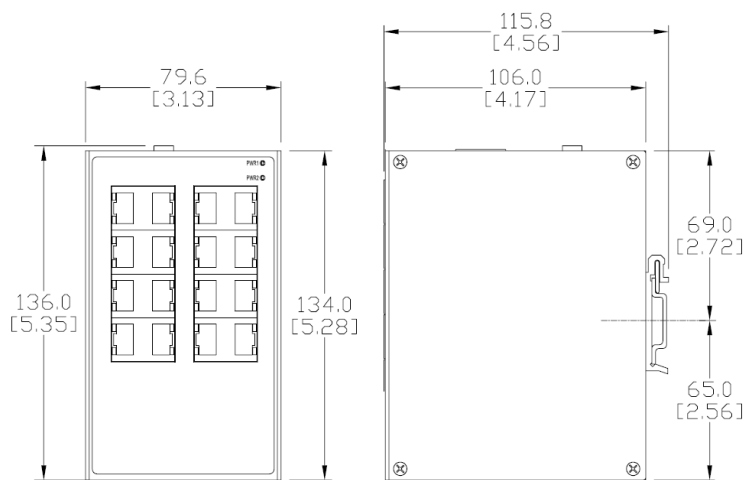

Figure 7: Ethernet Switch, 16 port (LT-ACC-ETS-16)

2.6.3 PoE Switch Specifications

Systems that use the Hub, PoE (LT-ACC-HUB-POE) require a PoE Ethernet switch. Xtralis provides two sizes of PoE Ethernet switches based on the number of ports they have. The table below lists the different options and their basic specifications. All PoE Ethernet switches are unmanaged models, and their ports meet IEEE 802.3af, Class 0.

Part Number	Number of Ports		Input Power Range
	RJ45 10/100	RJ45 10/100 PoE	
LT-ACC-POE-4	1	4	48 – 58 VDC (see section 2.2 for power consumption)
LT-ACC-POE-24	-	24	100 – 240 VAC, 50 – 60 Hz (see section 2.2 for power consumption)

Dimensions of each model are detailed below in mm/ [inches].

Note that Xtralis has multiple suppliers for the PoE ethernet switches, so exact dimensions may vary. For additional drawings and model files, please contact an Xtralis representative.

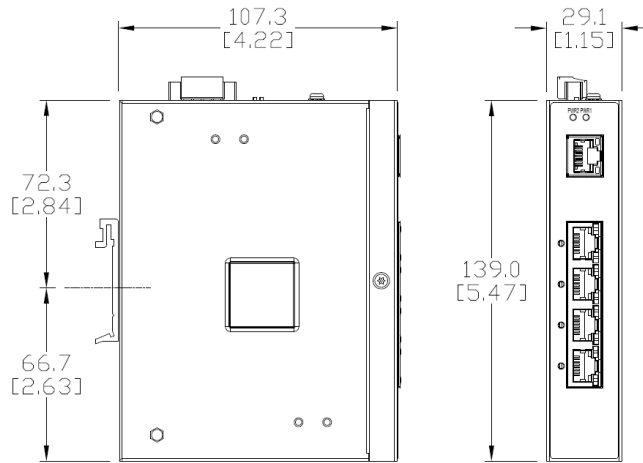

Figure 8: Ethernet Switch, PoE, 4 port (LT-ACC-POE-4)

Dimensioned drawing of the Ethernet Switch, PoE, 24 port (LT-ACC-POE-24) is unavailable; however, the dimensions are 440 x 257 x 44 mm (17.3 x 10.1 x 1.7 in).



Figure 9: Ethernet Switch, PoE, 24 port (LT-ACC-POE-24)

2.6.4 Relay Module Specifications

The Li-ion Tamer GEN 3 system includes an optional relay module (LT-ACC-ERO-16), which connects to the Controller to provide Form C relay dry contact outputs. Each relay module, depicted below, includes up to 16 SPDT Form C relay contacts. If more relays are required, the units can be daisy-chained via RS-485 to increase relay capacity.



Figure 10: Ethernet Relay Module, 16 port (LT-ACC-ERO-16)

General specifications for the relay module are listed in the table below:

Relay Module Specifications		
Input	Input Power Range	9 – 30 VDC (see section 2.2 for power consumption)
	Communication Signal Type	Modbus TCP/IP over Ethernet
Output	Type	16 SPDT Form C relays
	Power	DC 30 W/ AC 60 VA
	Contact Voltage	60 VDC max./ 50 VAC max.
	Contact Current	2 A max.

Relay Module Specifications		
	Operate Time/ Bounce Time/ Release Time	2 ms/ 7 ms/ 1 ms max.

Dimensions of the relay module are detailed below in mm/ [inches]:



2.7 Li-ion Tamer Part Numbers

The full list of Li-ion Tamer GEN 3 component part numbers is detailed below:

Part Number	Item	Description	Net Material Weight
LT-SEN-M3	Monitoring Sensor, Gen 3	Mounted on/near Li-ion battery rack to detect off-gas from cells	70 g
LT-SEN-R3	Reference Sensor, Gen 3	Mounted around the ESS	70 g
LT-ACC-HUB-PWR	Hub, Direct Power, Gen 3	Originates daisy-chain connection with sensors, powered directly with 12 VDC terminal block, includes terminator	200 g
LT-ACC-HUB-POE	Hub, PoE, Gen 3	Originates daisy-chain connection with sensors, powered via PoE, includes terminators	200 g
LT-ACC-HUB-MKT	Hub DIN-Rail Mount Kit	DIN rail mounting kit for the hubs	50 g
LT-CTR-SML	Controller, Gen 3	Controller that aggregates up to 100 sensor signals and generates integrate-able outputs.	1.5 kg
LT-CTR-SML-DMK	Controller DIN-Mount Kit	DIN rail mounting kit for controller	50 g
LT-ACC-POE-4, -24	Ethernet Switch, PoE, 4 and 24 Ports	PoE Ethernet switch for powering and transmitting signals from the Hub, PoE	460 g, 4.1 kg
LT-ACC-POE-24-ADR	PoE Switch 24 port, IEC Power Adapter	IEC plug to screw terminal adapter for the Ethernet Switch, PoE, 24 port	50 g
LT-ACC-ETS-5, -8, -16	Ethernet Switch, 5, 8, and 16 Ports	Ethernet switch for transmitting TCP/IP signals between system components	390 g, 500 g, 750 g
LT-ACC-ERO-16	Ethernet Relay Module, 16 Ports	Ethernet relay module with 16 SPDT Form C Relay terminals	544 g
LT-ACC-ERO-MKT	Relay Output DIN-Rail Mount Kit	DIN rail mounting kit for the relay module	50 g
LT-ACC-PWR-12, -48	Power Supply, 12VDC and 48VDC	Power supply for system with 12VDC and 48VDC options	600 g, 600 g
LT-ACC-SAK	Spare Kit - 4xTerminator 1xScrew Terminal Adapter	Spare Kit – 4x terminators 1x barrel plug to screw terminal adapter	50 g
LT-ACC-NCL-3, -5, -10, -25, -50, -100	3, 5, 10, 25, 50, 100 (ft) Network Cable	Shielded RJ45 connector cable used to connect sensors, hubs, ethernet switches, and controllers	130 g, 150 g, 170 g, 400 g, 800 g, 1.6 kg
LT-ACC-TST	DEC Bump Test Bottle	A plastic bottle with a small amount of DEC for use during bump testing of sensors	64 g
LT-DKT	Demo Kit, Gen 3	Case comprising representative system components	7.4 kg



Note!

Xtralis uses multiple suppliers for the LT-ACC-POE and LT-ACC-ETS parts to minimize the impact of supply chain interruptions. All parts with the same SKU have the same performance specifications, regardless of supplier.

3 Application

3.1 Sensor Placement

The following sections are general guidelines for sensor placement. Precise location and orientation are to be determined by a trained Xtralis representative upon installation. Refer to the Li-ion Tamer Design Guide (36094) for more design details.

3.1.1 Monitoring Sensor Placement

The Monitoring Sensors are to be placed near or on the battery rack to detect the release of electrolyte solvent vapours from the rack. While airflow is not required for sensor operation, the air flow patterns should be taken into consideration when positioning the Monitoring Sensors. Several examples of potential air-flow patterns and their corresponding sensor placement are shown on the following page.



Example #1

Type: air enters from the back of the rack and exits out the front
Sensor placement: top front of the rack
Sensor orientation: sensing face pointing down ($\pm 45^\circ$)



Sensing face
Pointing down



Example #2

Type: air enters from the top of the rack and exits out the bottom
Sensor placement: bottom center of the rack
Sensor orientation: sensing face pointing at 90° to vertical ($\pm 45^\circ$)



Sensing face
Pointing horizontal



Example #3

Type: air enters from the bottom of the rack and exits out the top
Sensor placement: top center of the rack
Sensor orientation: sensing face pointing at 90° to vertical ($\pm 45^\circ$)



Sensing face
Pointing horizontal



3.1.2 Reference Sensor Placement

The Reference Sensors are to be distributed throughout the ambient environment to monitor air inlets into the system, such as HVAC exchangers, doors, and other media which can serve as air inlets. The following information may be used as guidelines for Reference Sensor placement. Refer to the Li-ion Tamer Design Guide (Doc. No. 36094) for more information.

1. Any entrance or exit locations to the battery space (doors, access points, etc.)
2. Any possible gas entry points to the battery space (forced air or passive vent, unsealed gaps, etc.)
 - Multiple points identified on one surface (i.e. geometric plane) can be monitored with one reference sensor if the separation distance between points is less than 1 meter (3 ft) and not obstructed by a physical barrier or airflow pattern that would prevent a gas entering from a point to be detected by a single monitor.
 - Ensure adequate separation between Monitoring and Reference Sensors. Reference Sensors should never be mounted near battery racks unless they are separated from the hot aisle by a physical barrier (i.e. HVAC barrier, ducting, etc.).
3. Any HVAC entry points into the battery space.

3.1.3 System Layout Example

The Li-ion Tamer Design Guide (Doc. No. 36094) should be referenced when designing a Li-ion Tamer GEN 3 system. Below is an example system layout indicating sensor location and wiring architecture.

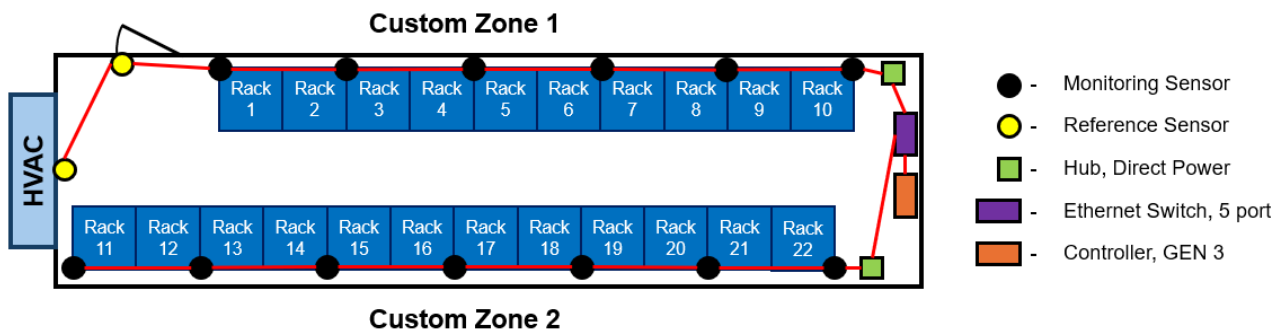

3.2 Signal Integration

The Li-ion Tamer controller has two primary outputs, including optional relay outputs, and Modbus serial communications, which are detailed in the next two sections.

3.2.1 Relay Output Integration

The relay modules have screw terminal blocks that are populated with Form C Relay contacts for up to 16 relays. The terminal blocks are compatible with 16 – 30 AWG wiring and provide dry contacts for direct integration into fire control panels, e-stop circuits, etc. *Refer to section 2.6.4 for more relay module specifications.*

The relay outputs are fully configurable via the controller's software user interface in the Settings Tab (see *section 4.2.6*). Options for relay outputs include the following:

- Watchdog (default populates Relay #1 on each relay module in use)
 - Normally energized
 - De-energizes upon power loss or communication loss with the controller
- System Alarm/ System Error
- Zone Alarm(s)/ Zone Error(s)
- Individual Sensor Alarm(s)/ Error(s)

The software user interface is used to add relay modules and assign output signals to relay positions.

The following steps detail how to setup the relay module(s) for integration:

1. Check that the Controller output is set to “Relays + Modbus TCP/IP” (see section 4.2.6).
2. Use a specification-compliant network cable to connect the Ethernet port on the relay module (shown below) to the Ethernet Switch that is connected to the Network 1 port on the Controller.

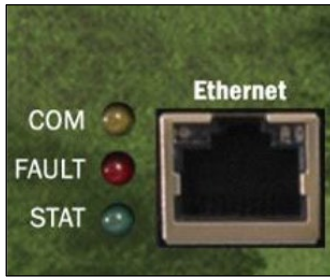

3. Download SeaMAX software from: <https://www.sealevel.com/support/software-seamax-windows/>.
4. Once SeaMAX software is installed, run it and it will automatically search for connected relay modules. When it locates a module, it will list it in the display as shown below:

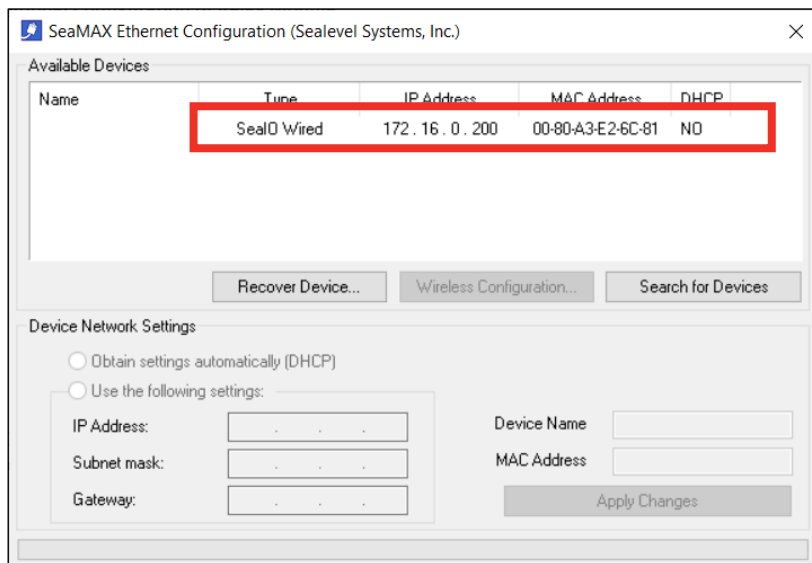

5. Select the relay module and under “Device Network Settings” select “Use the following settings” and input the settings below:
 - IP Address: 172.16.0.200
 - Subnet Mask: 255.255.0.0
 - Gateway: 172.16.0.1
6. Select “Apply Changes” and confirm that the device reappears with the configured settings.
7. Use a small screwdriver to set the ADDR dial on the relay module(s).

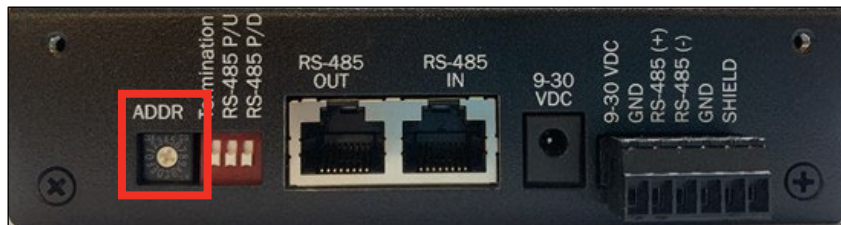

Note that each relay module that is connected to the same Controller will need to be assigned a unique ADDR, starting with 1 and increasing numerically in the order of the daisy-chain connections.

8. If using multiple relay modules with a single Controller, the expansion modules will be connected to the base module via RS-485, either using the designated RJ45 ports or screw terminals labeled for RS-485.
 - Each expansion module will need to have their ADDR dial set according to the Device Addresses in the relay mapping table.
 - Best practice is to have the ADDR setting match the order of daisy-chain connections in the RS-485 chain (example in the next page).

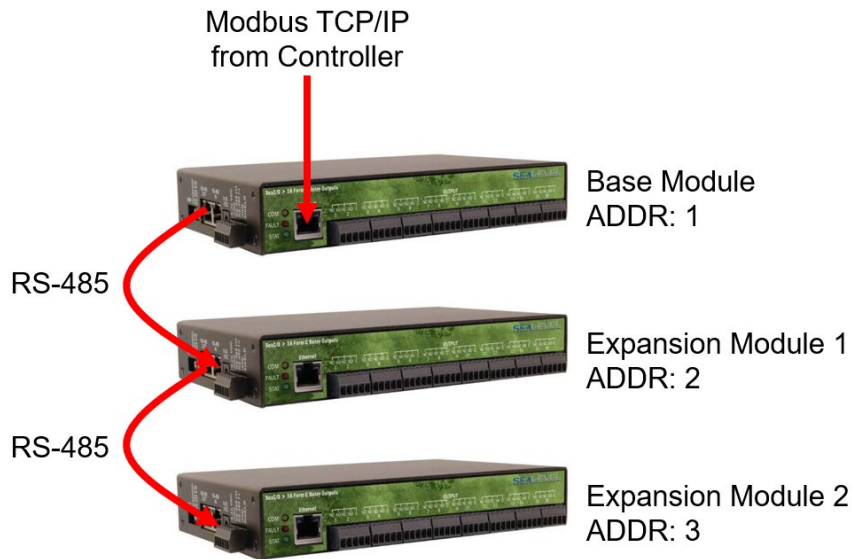

- Daisy-chained relay modules will also need their DIP switch settings changed. Location of the DIP switch block and settings for each module are detailed below. Note that ON is with the DIP switch in the up position and OFF is with it in the down position.
 - Base Module: *all switches ON*
 - Expansion Modules (except last in chain): *all switches OFF*
 - Last Expansion Module in Chain: *only Termination switch ON, other two OFF*

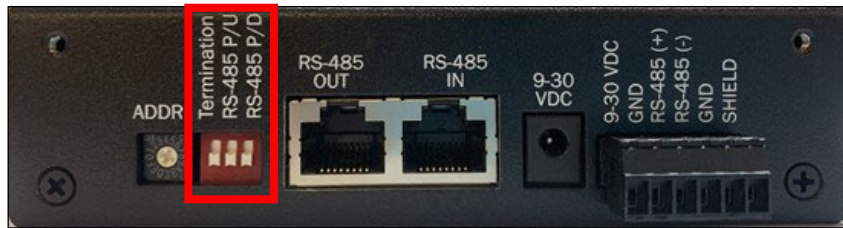

3.2.2 Modbus Output Integration

The Modbus TCP/IP output generated by the Controller is accessed using the Network 2 port on the Controller. This port utilizes static IP address settings with the default IP address listed below. The address settings may be changed in the software user interface (*section 4.2.6.1*).

Default Network 2 IP Address (CIDR)	192.168.199.199/24
Port	5020



Note!

The Modbus port, 5020, **cannot** be changed.

The only hardware required to integrate the Modbus TCP/IP output is a standard straight-through Ethernet cable, connecting the Controller’s Network 2 port to the customer’s system.

The Modbus TCP/IP addresses are detailed in the tables below:

Description	Function Code	Bit Address
System Error	01 (0x01)	1
System Alarm	01 (0x01)	2
Zone 1 Error	01 (0x01)	3
Zone 1 Alarm	01 (0x01)	4
Zone 1 Lockout	01 (0x01)	5

Description	Function Code	Bit Address
Zone 2 Error	01 (0x01)	6
Zone 2 Alarm	01 (0x01)	7
Zone 2 Lockout	01 (0x01)	8
Zone 3 Error	01 (0x01)	9
Zone 3 Alarm	01 (0x01)	10
Zone 3 Lockout	01 (0x01)	11
.	.	.
.	.	.
.	.	.
Zone 20 Error	01 (0x01)	60
Zone 20 Alarm	01 (0x01)	61
Zone 20 Lockout	01 (0x01)	62

Description	Function Codes	Integer and Floating-Point Number Address	
		Start	End
Number of Zones	04 (0x04)	1	1
Number of Sensors	04 (0x04)	2	2
Sensor 1 Data	04 (0x04)	16	20
Sensor 2 Data	04 (0x04)	21	25
Sensor 3 Data	04 (0x04)	26	30
.	.	.	.
.	.	.	.
.	.	.	.
Sensor 98 Data	04 (0x04)	501	505
Sensor 99 Data	04 (0x04)	506	510
Sensor 100 Data	04 (0x04)	511	515

Each sensor data grouping of registers is broken down based on the table below:

Register	1	2	3	4	5								
Bits	1 - 16	17 - 32	33 - 48	49 - 64	65 - 72	73	74	75	76	77	78	79	80
Data Type	16-bit uint	16-bit float	16-bit float	16-bit float	8-bit uint	byte	byte	byte	byte	byte	byte	byte	byte
Description	Sensor ID	Temperature (C)	Relative Humidity (%)	Scalar Value	Zone ID	Reserved	Reserved	Is Ref	Unplugged	Inactive	Active	Error	Alarm

4 Installation, Operation and Maintenance

4.1 System Installation

All installation should be performed by a trained Xtralis representative. The following steps outline the installation process:

1. Mount sensor(s).
2. Mount hub(s).
3. Mount Ethernet switches, controller, relay modules, and power supplies.
4. Route cables (*see section 4.1.6 for cable length limits*):
 - If applicable, locate the main cabling distribution area close to the central region of the installation site to minimize the cable distances.
 - Avoid mounting the cabling components in places that block accessibility to other equipment (such as a power strip or fans) in and out of the racks.
 - Label the cables with their destination at every termination point (to ensure that both the ends of the cable are labeled for identification and traceability).
 - Test every cable during installation and termination. If a problem occurs, tag the malfunctioning cables and separate them out.
 - Avoid exposing cables to areas of condensation and direct sunlight.
 - Utilize cable trays whenever possible.
 - Provide strain-relief when mounting cables to prevent connection issues.
 - Observe all recommended practices from the cable manufacturer including bend radius, etc.
5. Connect groups of sensors in a daisy-chain with their respective hub, with a terminator at the end of each chain.

WARNING: Ensure that cables are not in tension. Make sure to provide enough slack to avoid potential damage.



Note!

Connect network cables to the Hub output ports but **do not connect any Hubs to the Ethernet Switch(es) or Controller**. This step will happen during the system configuration process.

6. Follow configuration (*section 4.2*) and commissioning processes (*section 4.3*).

4.1.1 Sensor and Hub Installation

Sensors and Hubs come equipped with sets of four mounting holes, with two on each flange. The holes are spaced according to standard rack unit spacing (RU). Dimensioned drawings indicating hole spacing are shown below in mm/ [inches].

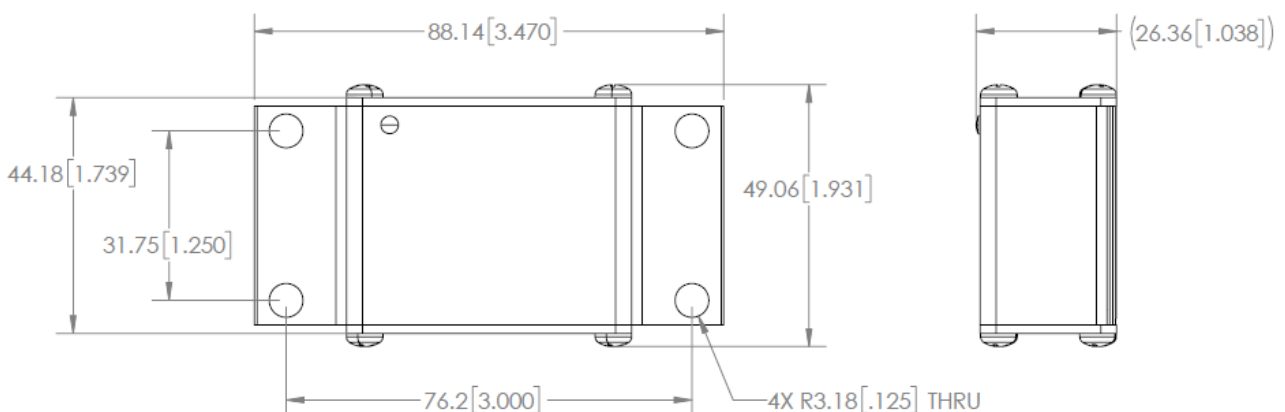

Figure 11: Monitoring/ Reference Sensor (LT-SEN-M3/ R3)

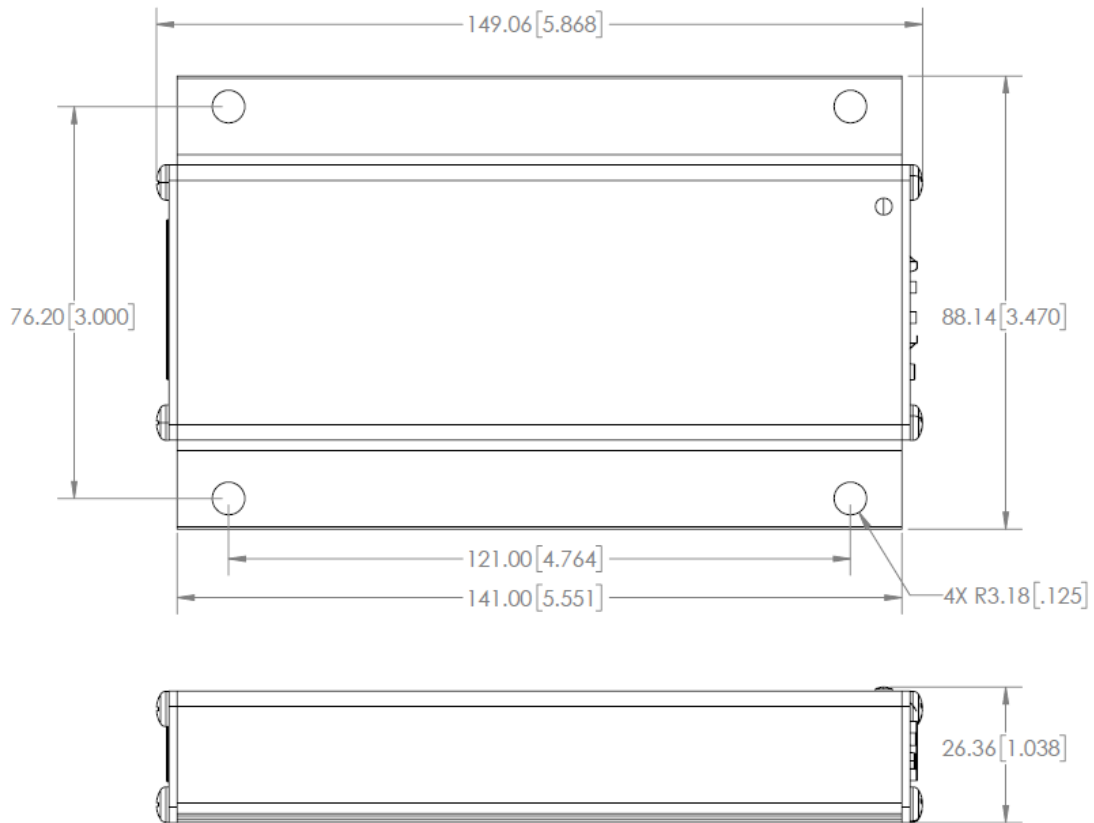
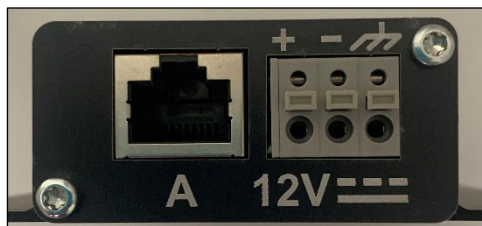



Figure 12: Hub, Direct Power/ PoE (LT-ACC-HUB-PWR/ POE)

Xtralis also provides an optional DIN-rail mounting kit (LT-ACC-HUB-MKT) for mounting the Hubs on a standard TS35/7.5 DIN rail. The kit includes two clips with adhesive strips to attach them to the backplate of the Hub.

The Sensors and Hub, PoE (LT-ACC-HUB-POE) will receive power from other components within the system architecture once connected with network cables. However, the Hub, Direct Power (LT-ACC-HUB-PWR) will require an additional power supply input via the terminal block shown below. See sections 2.5.1 and 2.5.2 for more details.



+	-	
+12 VDC	-VDC	Earth Ground
Input Voltage	12 VDC (see section 2.2 for power consumption)	
Wire Specifications	16 – 22 AWG stranded copper	

4.1.2 Ethernet Switch Installation

Both the standard and PoE Ethernet switches, with the exception of the LT-ACC-POE-24, are equipped with DIN-rail clips for mounting on a standard TS35/7.5 DIN rail. Allow 2 cm (0.79 inches) clearance around each switch for proper cooling.

The LT-ACC-POE-24 is a rack-mount unit that can be mounted on any standard size 19-inch (about 48 cm) wide rack. The switch requires 1 rack unit (RU) of space, which is 44.45 mm (1.75 inches) in height. To install in a 19-inch standard chassis, follow the steps below:

1. Place one of the supplied brackets on the side of the switch so that the four holes of the brackets align to the screw holes, and then use the four supplied screws to secure it.
If replacement screws are needed, they should meet the following size requirements: 6.9mm screw head diameter, 5.9mm fully threaded length and 3.94mm shaft diameter.
2. Repeat the previous step to attach the other bracket to the opposite side of the switch.
3. After the brackets are securely attached, the switch is now ready to be installed into a standard 19-inch rack, as shown below.

To prevent airflow restriction, allow clearance around the ventilation openings to be at least 3 inches (7.6 cm).

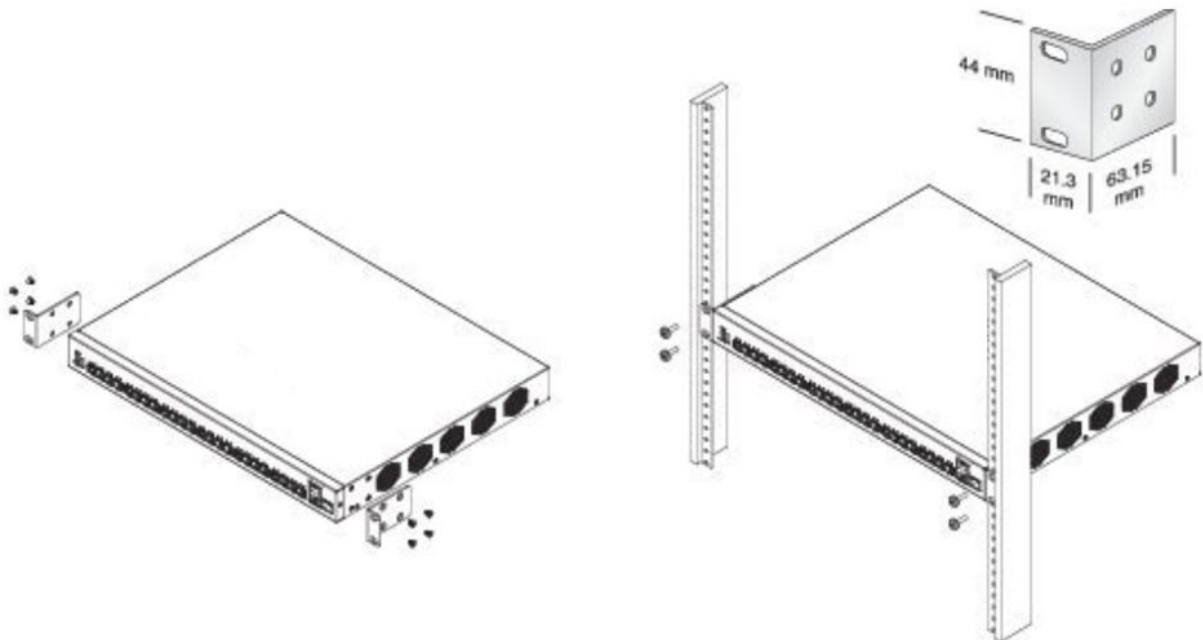

Ethernet switch power input requirements are detailed below:

Ethernet Switch Power Input Wiring	
<i>Ethernet Switch, 5, 8, and 16 Port (LT-ACC-ETS-5, -8, -16)</i>	
Power Input	Input screw terminals Connect chassis to Earth GND
Input Voltage	12 – 48 VDC (see section 2.2 for power consumption)
Wire Specifications	12 – 24 AWG stranded copper Max wire length: 3m (9.84 ft)
<i>Ethernet Switch, PoE, 4 Port (LT-ACC-POE-4)</i>	
Power Input	Input screw terminals Connect chassis to Earth GND
Input Voltage	48 – 58 VDC (see section 2.2 for power consumption)
Wire Specifications	16 – 24 AWG stranded copper Max wire length: 3m (9.84 ft)

Ethernet Switch, PoE, 24 Port (LT-ACC-POE-24)	
Power Input	C14 IEC inlet Xtralis provides an IEC C13 to screw terminal adapter (LT-ACC-POE-24-ADR) – (dimensions below)
Input Voltage	100 – 240 VAC, 50 – 60 Hz (see section 2.2 for power consumption)
Wire Specifications	14 – 16 AWG stranded copper

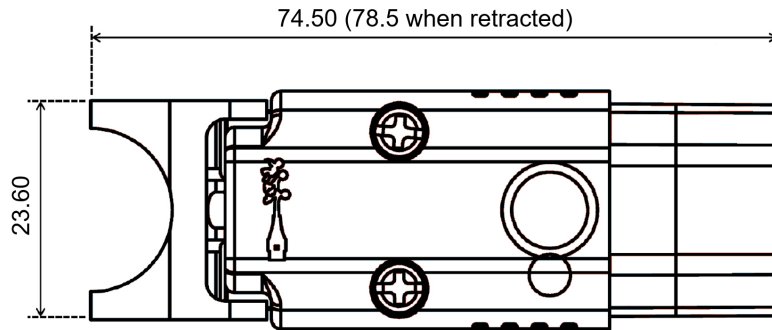

Figure 13: PoE Switch 24 Port, IEC Power Adapter (LT-ACC-POE-24-ADR)

4.1.3 Controller Installation

The Controller, GEN 3 (LT-CTR-SML) does not include any mounting hardware, therefore Xtralis provides a DIN-rail mounting kit (LT-CTR-SML-DMK) for mounting on a standard TS35/7.5 DIN rail. Allow 1cm (0.39in) clearance around each Controller for proper cooling.

Controller power input requirements are detailed below:

Controller Power Input Wiring	
Power Input	Barrel plug Xtralis provides barrel plug to screw terminal adapter as part of LT-ACC-SAK
Input Voltage	12 VDC (see section 2.2 for power consumption)
Wire Specifications	14 – 24 AWG stranded copper Max wire length: 3m (9.84 ft)



Note!

The Controller does not include screw terminals for power input. Therefore it is recommended to purchase 1x LT-ACC-SAK for each Controller. The Spare Accessory Kit includes necessary hardware for powering Controllers with a screw terminal input.

The steps below detail how to properly secure the barrel plug to screw terminal adapter to the Controller using the barrel plug lock:

1. Remove the small screw below the Controller barrel jack shown below:



2. Insert the barrel plug to screw terminal adapter into the barrel jack.

- Position the barrel plug lock as shown below and use the previously removed screw to fasten the lock to the Controller.
Make sure that the barrel plug is fully inserted into the jack.



4.1.4 Relay Module Installation

The Ethernet Relay Module, 16 port (LT-ACC-ERO-16) does not include any mounting hardware, therefore Xtralis provides a DIN-rail mounting kit (LT-ACC-ERO-MKT) for mounting on standard TS35/7.5, TS35/10, and TS35/15 DIN rails. See below for an example of DIN-rail mounting kit installation.

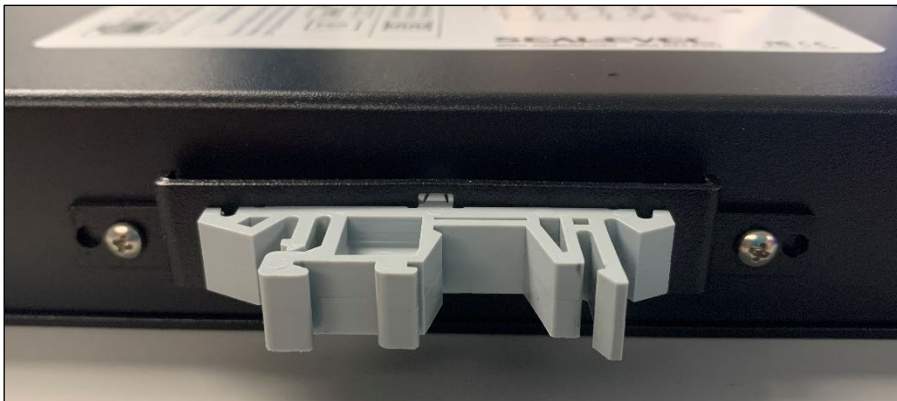

Ethernet Relay Module, 16 port power input requirements are detailed below:

Relay Module Power Input Wiring	
Power Input	Screw terminals or barrel plug
Input Voltage	9 – 30 VDC (see section 2.2 for power consumption)
Wire Specifications	14 – 24 AWG stranded copper Max wire length: 3m (9.84 ft)

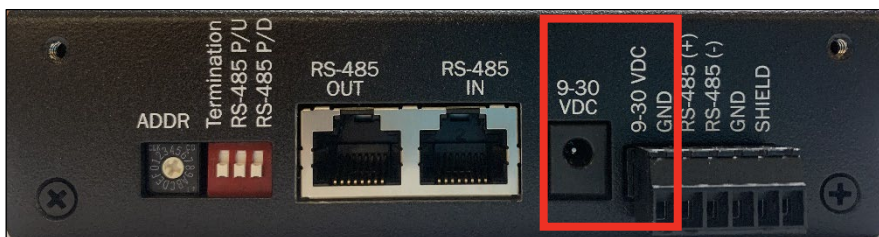

If using multiple relay modules with a single Controller, the expansion modules will be connected to the base module via RS-485, either using the designated RJ45 ports or screw terminals labelled for RS-485 (see section 3.2.1).

There are two options for wiring expansion modules, as follows:

1. **RJ45 (Pass-Through) Ports:** The RJ45 ports may be used to connect expansion modules to the base module over RS-485. They are also equipped with pass-through power so daisy-chained modules will receive power from the base module.
 - Maximum Distance Between Modules: 3 meters (10 ft)
 - Do not attempt Option 2 if the RJ45 ports are already in use, as this could cause hardware damage.



Note!

Daisy-chaining RS-485 over the RJ45 ports is limited to 3x modules as the pass-through power connection can only support 1.2A. If more modules are being daisy-chained, use the screw terminal option detailed below.

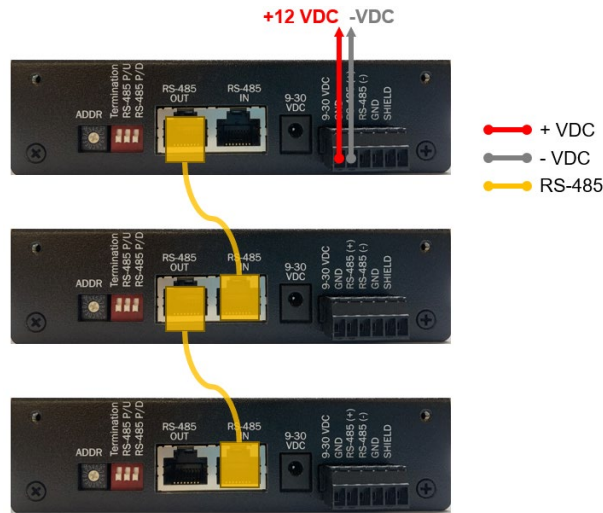

2. **Screw Terminals:** The screw terminals may be used to connect expansion modules to the base module over RS-485. Unlike the RJ45 connections, the RS-485 screw terminal connections are only for RS-485 and do not simultaneously provide pass-through power. For ease of wiring, the modules may have their “9-30 VDC” and “GND” screw terminal connections daisy-chained so they are wired in parallel with the power supply, as shown below.

- Maximum RS-485 Distance (entire chain): 1000 meters (3280 ft)
- Additional power supplies may be needed due to voltage drop limitations of daisy-chained power wiring.
- Use twisted-pair cables with shielding connected to earth ground on only one end.

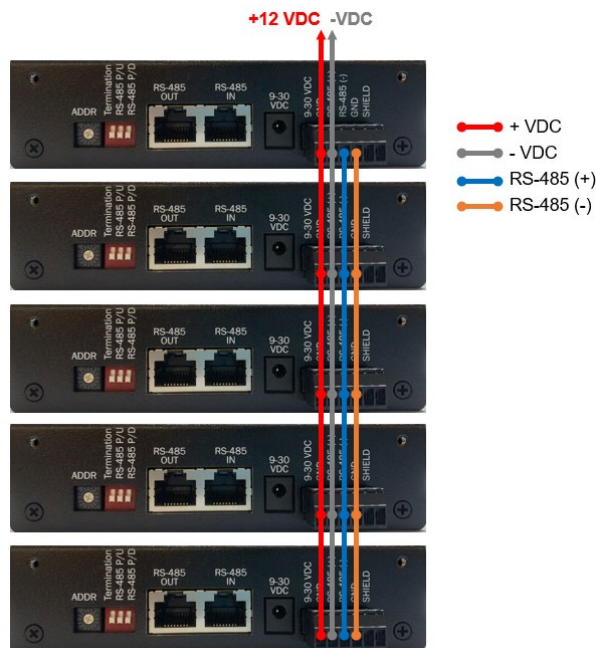

4.1.5 Power Supply Installation

The power supplies (LT-ACC-PWR-12, -48) are DIN-rail mountable and fit TS35/7.5 and TS35/15. Refer to the Mean Well installation manual (<https://www.meanwell.com/Upload/PDF/NDR%20DIN%20rail.pdf>) for more mounting details.

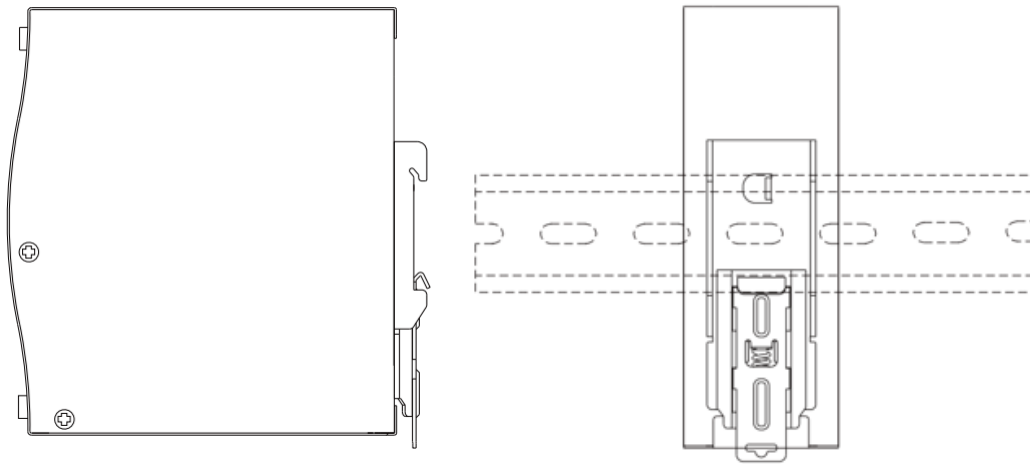

A terminal cover is included in the Spare Accessory Kit (LT-ACC-SAK), shown below, to help protect the AC input screw terminals on the power supply.



The steps below detail how to properly attach the terminal cover to the power supply:

1. Remove the screw on the power supply that is adjacent to the AC input screw terminals, shown below:



2. The spare accessory kit contains a screw that is the same size as the one removed in Step 1, but it is longer. Use this screw to fasten the terminal cover to the power supply as shown below.
 - A zip tie may also be used to fasten the AC power cable to the holes on the terminal cover.

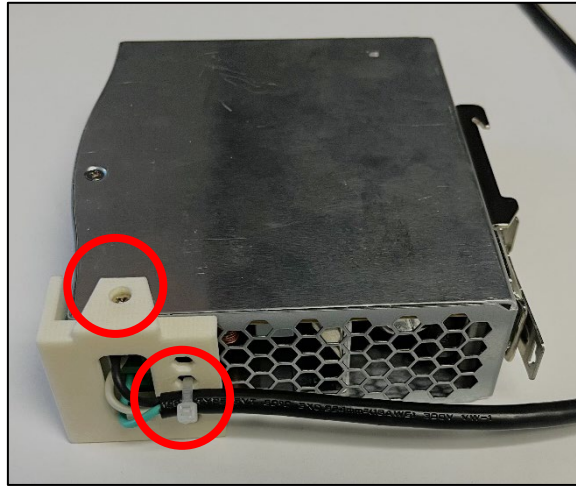

4.1.6 Cable Length Limitations

The network cables shall meet the specifications in the Li-ion Tamer GEN 3 Engineering Specification (*Doc. No. 37143*) and conform to the following maximum cable lengths between devices:

- Controller to Ethernet Switch (standard or PoE): 100 meters (328 ft)
- Ethernet Switch (standard or PoE) to Hub (Direct Power or PoE): 100 meters (328 ft)
- Hub (Direct Power or PoE) to first Sensor: 30 meters (98 ft)
- Sensor to Sensor: 30 meters (98 ft)
- Hub (Direct Power or PoE) to last Sensor in chain: 100 meters (328 ft)

4.2 System Configuration (Software)

Configuration of the Li-ion Tamer GEN 3 system is done using the controller’s software user interface. The following sections detail the different functions of the software and demonstrate the process for properly configuring an example system.

The sample system is depicted below.

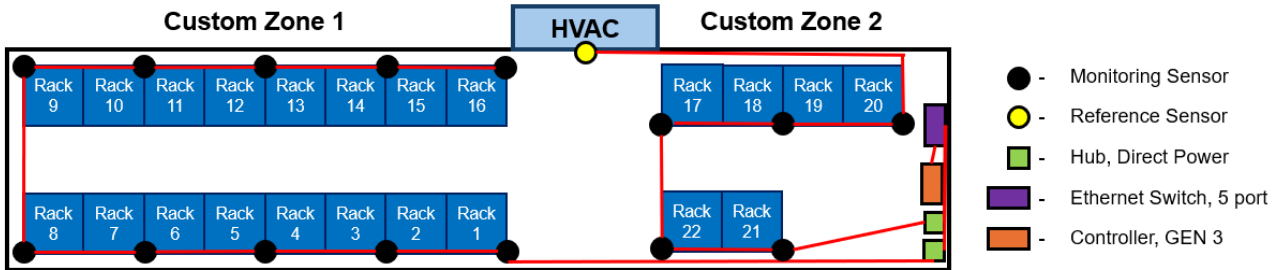

4.2.1 Configuration Preparation

To start configuring the system using the software user interface, the controller must be powered, the ethernet switch must be connected to the controller’s Network 1 port, and a computer or laptop must be connected to the ethernet switch with a network cable.

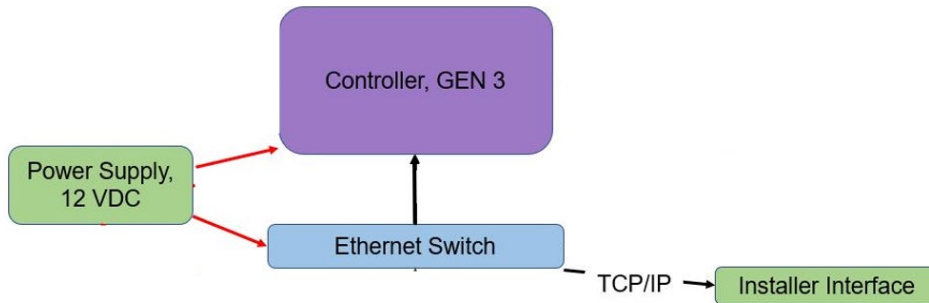

4.2.2 Login and Initial System Setup

Once the controller is powered and connected to a computer, proceed with the following steps:

1. Open a web browser and enter this URL: <https://172.16.0.1>
 The browser may flag the URL as being not trusted or secure, in this case go to the advanced settings and proceed to the URL.
 The login screen, shown below, is the first screen that will be displayed when first connecting to the controller’s user interface.

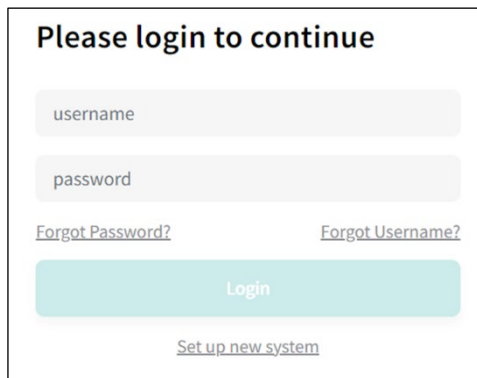

2. Enter your credentials if you have already created a user, click “Login”, select “Configure Sensors” at the top right corner of the **Dashboard** and skip to *section 4.2.3*.

- If you forgot your password, select “Forgot Password?” and follow the prompts to reset it. Note that resetting the password requires an admin’s username and the controller’s serial number, shown below:

Forgot Password?

Please enter an admin username and the serial number of the controller.

Username
testadmin

Serial number from controller
U872363

Done Next



- If you forgot your username, select “Forgot Username?” and follow the prompts to get a reminder of the active usernames.

Forgot Username?

Please enter the serial number of the controller.

Serial number from controller
U872363

Done Next

Forgot username?

Users

T testad***

Done

3. If you have not created a user before, click “Set up new system”, the following page appears:

NETWORK SETUP

1. Register an administrator user

testadmin

.....

.....

Register

4. Enter an administrator’s username and password, each in its field.



Security Note!

Use secure password best practices. A secure password consists of the following:

- At least 10 characters
- A mixture of both uppercase and lowercase letters
- A mixture of letters and numbers
- Inclusion of at least one special character, e.g., ! @ # ?]

5. Click “Register”, the following page appears:

NETWORK SETUP

2. System setup

Monitoring Sensors
10

Reference Sensors
2

Number of zones
2

Controller Output
Modbus TCP/IP
Modbus TCP/IP
Relays + Modbus TCP/IP

- 6. Enter the total number of Monitoring Sensors, Reference Sensors and Zones, each in its respective field.
- 7. Select the controller output that will be integrated.
Note that all these settings can be changed later.
- 8. Click “Next”, the following page appears:

NETWORK SETUP

3. Next up

Add additional users >

Configure Sensors >

This page provides you with two options: “Add additional users” or “Configure Sensors”.

- **Add Additional Users:**

This option navigates to the **Users** tab and displays the “Register a user” pop-up through which you can create new Admin or Installer users. *Refer to section 4.2.5 for more information on the **Users** tab.*

Register a user

Username
username

Role
Installer

Password
password

Repeat password
repeat password

Cancel Register user

Register a user

Username
testinstaller

Role
Installer

Password
installerpassword

Repeat password
installerpassword

Cancel Register user



- **Configure Sensors:**
This option navigates to the **Configure Sensors** screen where you can continue setting up the system. Refer to section 4.2.3 for more information.

4.2.3 Configure Sensors

Through the **Configure Sensors** screen you can connect sensors and hubs to the controller, place them in zones and distribute Reference Sensors across multiple zones.



Every system must have at least one zone.

1. Click “Add New Zone” to create a zone, a pop-up appears as shown below:

2. Enter an appropriate zone name.
3. Enter the number of Monitoring Sensors and Reference Sensors.
Note that these settings can be changed later, if necessary.
4. Click “Create Zone”.
5. Select the zone from the left menu and connect the hub(s) in that zone to the controller via the Ethernet switch(es).
 - Wait for the hub(s) to appear in the zone and for their LED(s) to stop flashing blue. Note that it may take a couple minutes for the hub to fully connect and for the LED to indicate normal operation (see section 2.5.3). Re-select the zone in the left menu to refresh.



Note!

If the hubs and sensors experience any errors while connecting, refer to section 4.3.2.

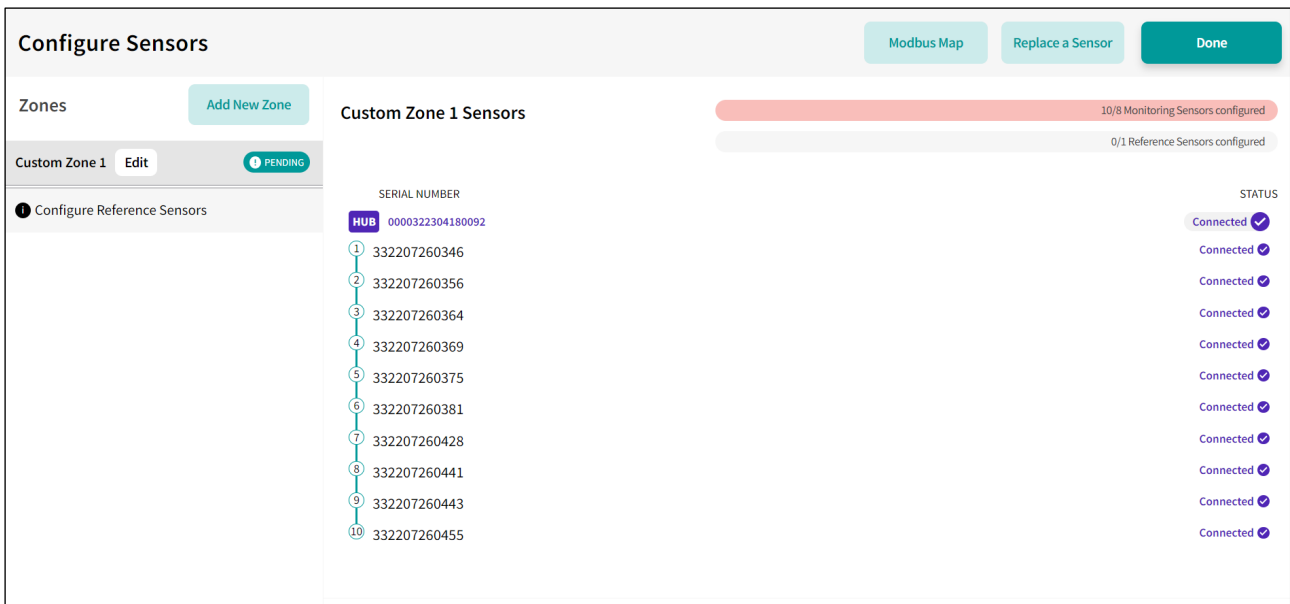

- Once the hubs connect to the software, their serial numbers, the serial numbers of the connected sensors and their statuses will be listed. The progress bars will also fill relative to the sensor quantities.
- If the zone is listed as “Pending”, it indicates that either of the two progress bars are unfilled or red, so check that the physical sensor quantities in the zone match what’s defined in the zone settings.
- You can click “Edit” to modify the zone’s settings and fix any errors.

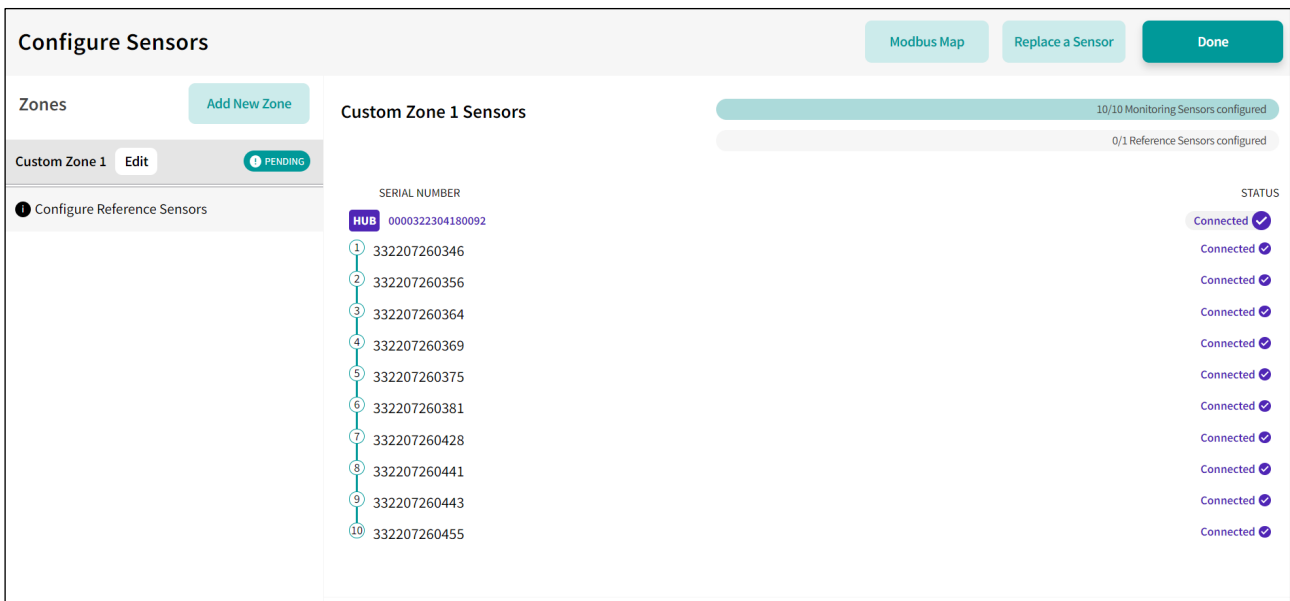

6. Repeat the above steps to define the remaining zones in the system.

Configure Sensors [Modbus Map] [Replace a Sensor] [Done]

Zones [Add New Zone]

Custom Zone 1 [PENDING]

Custom Zone 2 [Edit] [CONFIGURED]

1 Configure Reference Sensors

Custom Zone 2 Sensors 5/5 Monitoring Sensors configured
1/1 Reference Sensors configured

SERIAL NUMBER	STATUS
HUB 0000322206270002	Connected ✓
1 332207110026	Connected ✓
2 332207110031	Connected ✓
3 332207110033	Connected ✓
4 332207110037	Connected ✓
5 332207110038	Connected ✓
6 342207110098 Reference	Connected ✓

Additional Reference Sensors
Reference Sensors previously added to other Zones. Add them from "Configure Reference Sensors"

- Reference Sensors can be shared between multiple zones, even if they are not physically connected to the hubs in those zones.
- Example: Custom Zone 1 in the sample system requires 1x Reference Sensor, but there are no Reference Sensors connected to the hub.

Configure Sensors [Modbus Map] [Replace a Sensor] [Done]

Zones [Add New Zone]

Custom Zone 1 [Edit] [PENDING]

1 Configure Reference Sensors

Custom Zone 1 Sensors 10/10 Monitoring Sensors configured
0/1 Reference Sensors configured

SERIAL NUMBER	STATUS
HUB 0000322304180092	Connected ✓
1 332207260346	Connected ✓
2 332207260356	Connected ✓
3 332207260364	Connected ✓
4 332207260369	Connected ✓
5 332207260375	Connected ✓
6 332207260381	Connected ✓
7 332207260428	Connected ✓
8 332207260441	Connected ✓
9 332207260443	Connected ✓
10 332207260455	Connected ✓

- To add Reference Sensors to a zone, click "Configure Reference Sensors".
- Make sure each Reference Sensor is added to the appropriate zone(s), based on the system design, by selecting them from the menus shown in the next page:

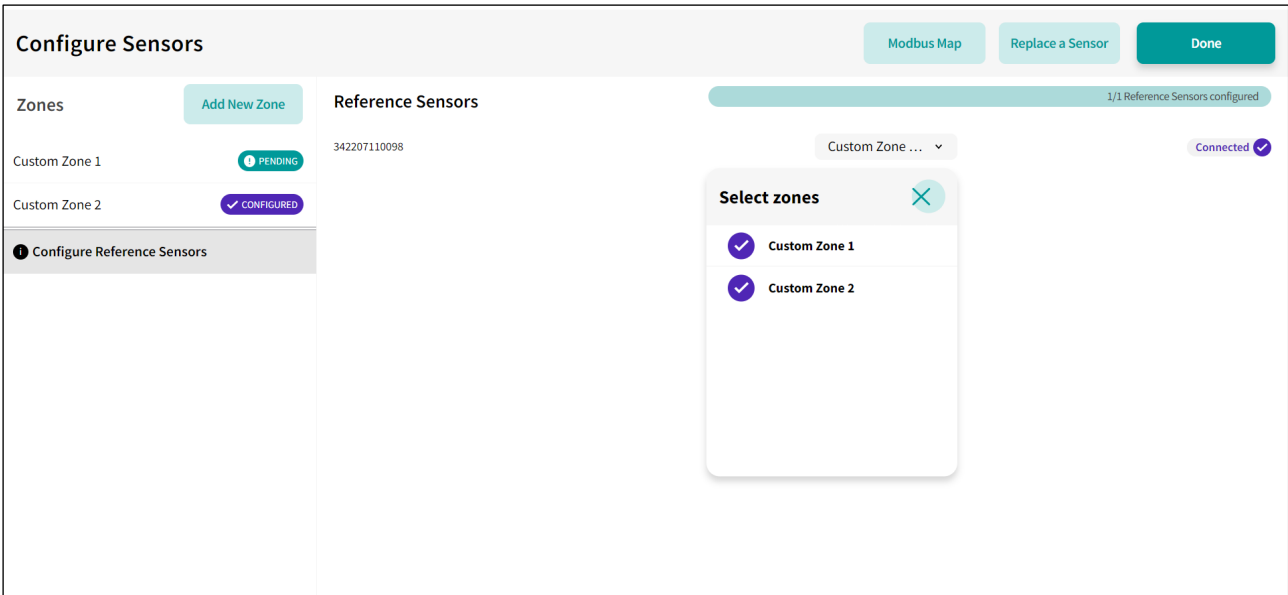

- Reference Sensors that are added to zones will appear in the **Additional Reference Sensors** section under those zones, as shown below:

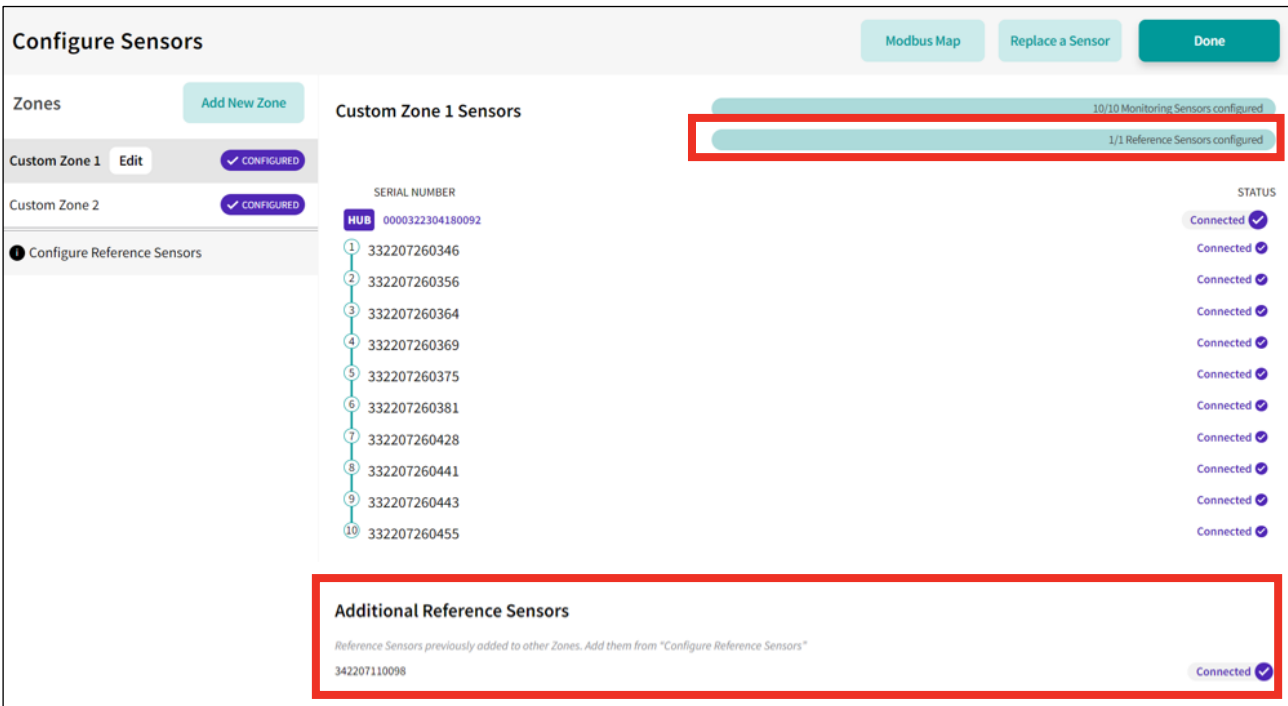

7. Make sure all hubs and sensors are connected to the controller via Ethernet switch(es), and all zones are properly "Configured".
8. Click "Done" and proceed to *section 4.3* to commission the configured system.



Note!

Guidelines for Connecting/ Swapping Hubs and Sensors:

- Always wait for hub LED(s) to stop flashing blue before switching zones
- Power down affected hub(s) before swapping sensors
- Always enter Configure Sensors mode before adding or removing hubs/ sensors

4.2.3.1 Replace Sensor Tool

The **Configure Sensors** screen includes a tool to assist with sensor replacements. It will transfer information from the old sensor, such as sensor name and relay/ Modbus assignments, and will apply them to the new sensor.



To replace a sensor, follow these steps:

1. Enter the **Configure Sensors** screen and select the Zone containing the sensor that needs to be replaced.
2. Identify the Hub that the target sensor is connected to and power it OFF.
3. Wait for the Hub/ sensor chain to disappear from the Zone's list (approximately 1 minute).
4. Manually remove the old sensor and connect the new sensor in its place.
5. Power the Hub/ sensor chain back ON and wait for it to connect and appear in the Zone's list.
6. Click "Replace a Sensor" to open the following pop-up:

7. Select the old and new sensor's serial numbers from the drop-down menus. Serial number is on the sensor's barcode label.

8. Click "Swap".

4.2.3.2 Modbus Map Tool

Another feature of the **Configure Sensors** screen is the Modbus Map Tool, which is used to sort the sensor data on the input registers of the Modbus output (*section 3.2.2*). It is especially useful to ensure the Modbus output aligns with the customer control system’s expected mapping.



Note!

It is recommended to name the sensors prior to using the Modbus Map Tool (*section 4.2.4.1*).



To sort the Modbus map, follow these steps:

1. Click “Modbus Map” on the **Configure Sensors** screen.
2. The tool contains two lists, “Included in Modbus” and “Excluded from Modbus”.

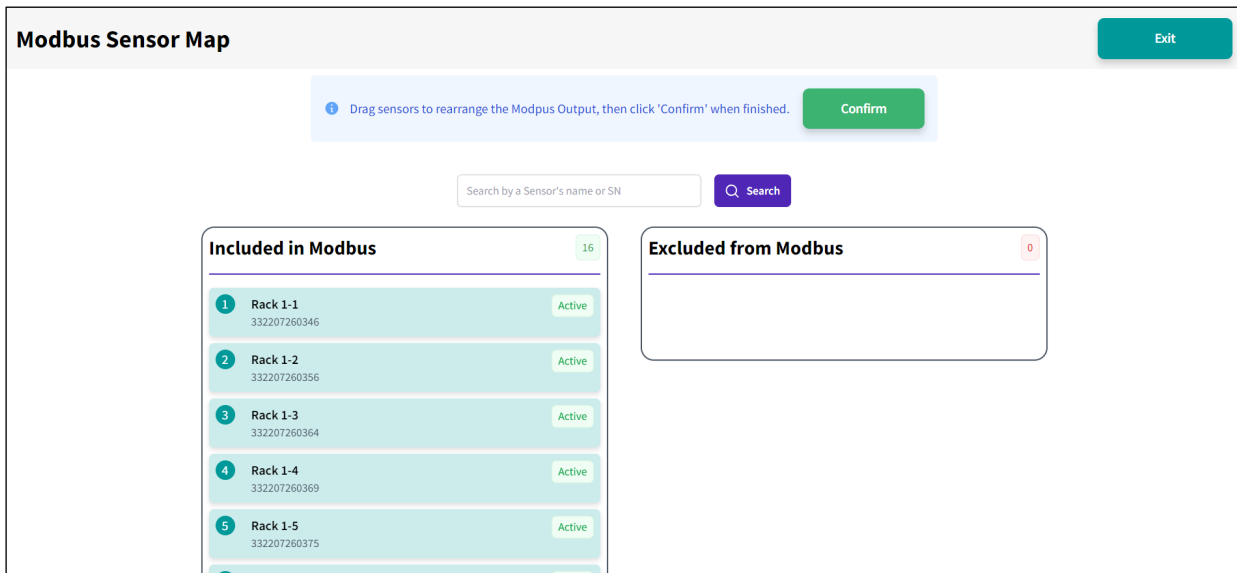

If the sensors are not named, their serial numbers will be listed (below left). Named sensors’ name will be displayed (below right).

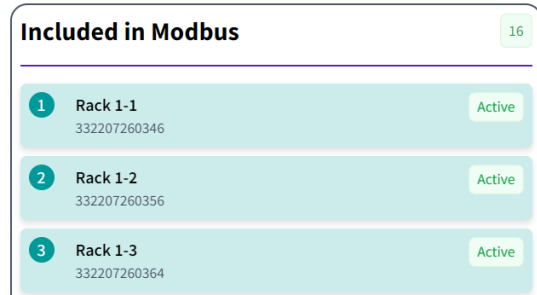
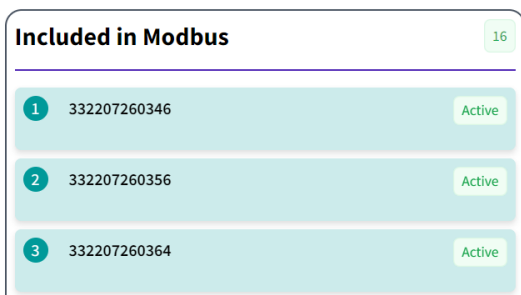

3. Drag-and-drop sensors to change the order of the Modbus sensor data.
 - To remove a sensor from the Modbus output, place it in the “Excluded from Modbus” list.
 - The search function can be used to locate a sensor’s serial number or name in the lists.

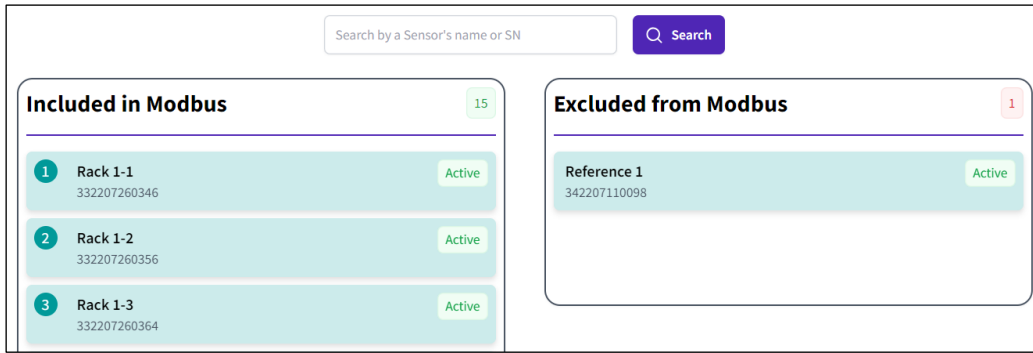

4. Click “Confirm” and verify the changes were successful.

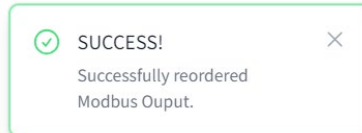

5. Click “Exit” to close the tool.

4.2.4 Dashboard

The **Dashboard** provides a real-time view of the Li-ion Tamer system, including all zones, hubs, and sensor statuses. As shown below, zones are listed with their overall statuses indicated and their respective hubs and sensors listed.

Additional information listed for each sensor includes, from left to right, the FW Version, Type of Sensor, Temperature, Relative Humidity, and Scalar Value.

The dashboard shows two zones: 'Custom Zone 1' and 'Custom Zone 2'. Each zone has a hub and several monitoring sensors, plus a reference sensor. The table below summarizes the data shown in the screenshot.

Zone	Item	Name	FW Version	Type	Status	Temperature	Humidity	Scalar Value	Sensor Standby
Custom Zone 1	Hub	0000322304180092	1.20.8		ok				Connected
	1	332207260346	1.20.3	monitoring	ok	25.1°C	20.1%	0.00	Off
	2	332207260356	1.20.3	monitoring	ok	24.9°C	20.5%	0.01	Off
	3	332207260364	1.20.3	monitoring	ok	25.1°C	20.6%	0.01	Off
	4	332207260369	1.20.3	monitoring	ok	25.0°C	20.4%	0.01	Off
	5	332207260375	1.20.3	monitoring	ok	25.1°C	20.7%	-0.02	Off
	6	332207260381	1.20.3	monitoring	ok	24.8°C	20.8%	0.01	Off
	7	332207260428	1.20.3	monitoring	ok	24.8°C	20.9%	-0.01	Off
	8	332207260441	1.20.3	monitoring	ok	24.9°C	20.9%	-0.00	Off
	9	332207260443	1.20.3	monitoring	ok	24.7°C	21.0%	-0.01	Off
	10	332207260455	1.20.3	monitoring	ok	24.5°C	21.3%	0.02	Off
Reference	342207110098	1.20.3	reference	ok	24.1°C	20.7%	-0.03	Off	
Custom Zone 2	Hub	0000322206270002	1.20.8		ok				Connected
	1	332207110026	1.20.3	monitoring	ok	24.2°C	21.0%	-0.01	Off
	2	332207110031	1.20.3	monitoring	ok	24.1°C	20.9%	0.00	Off
	3	332207110033	1.20.3	monitoring	ok	24.0°C	20.8%	0.01	Off
	4	332207110037	1.20.3	monitoring	ok	24.2°C	20.7%	-0.02	Off
	5	332207110038	1.20.3	monitoring	ok	24.1°C	20.8%	0.01	Off
	Reference	342207110098	1.20.3	reference	ok	24.1°C	20.7%	0.01	Off

The hub and sensor serial numbers are listed, with the icon next to each serial number indicating the physical connections in the system. For example, in the image below, the hub has ten sensors in the chain that is connected to it. The remaining sensor is a Reference Sensor that has been added to this zone but is not physically connected to any hubs in the zone.

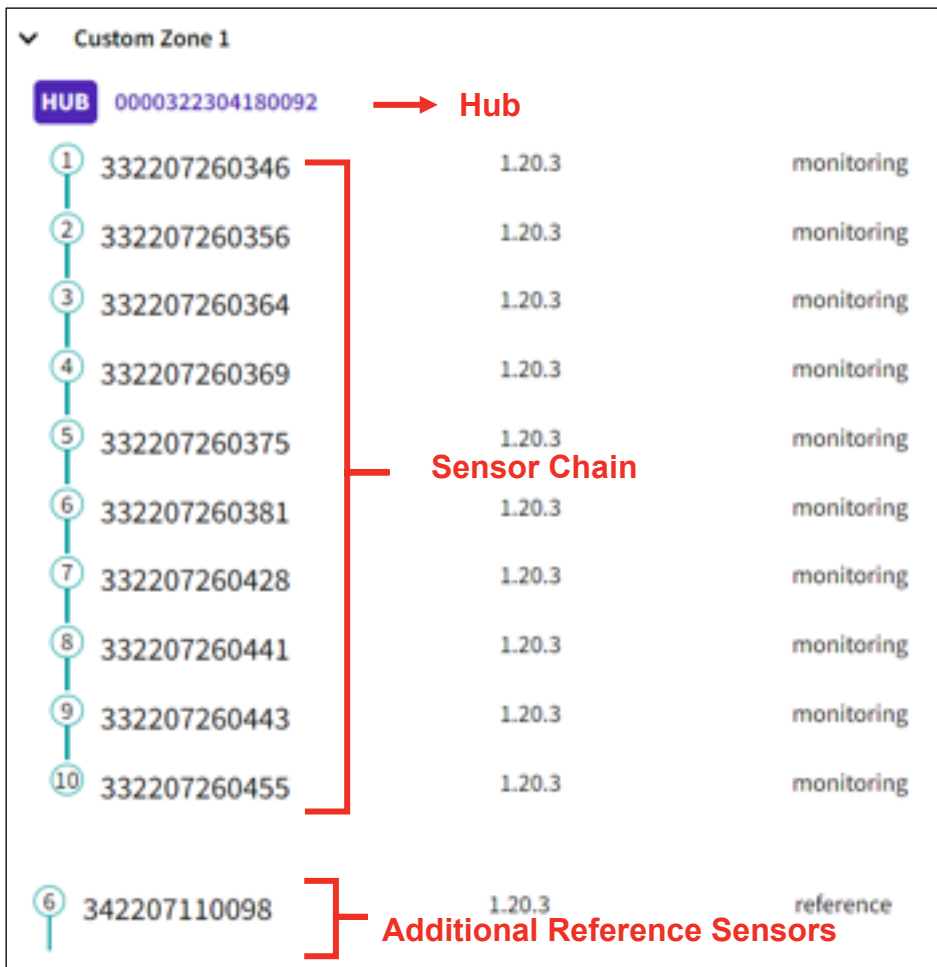

The Hub statuses are shown on the right side of the screen, with two examples shown below:



The **Dashboard** display can also be compacted to only show zone statuses by selecting the dropdown arrow next to the zone's name. The compacted version of the **Dashboard** is shown below:

Name	FW Version	Type	Status	Temperature	Humidity	Scalar Value	Sensor Standby
> Custom Zone 1			● ok				
> Custom Zone 2			● ok				

Any system-level notifications, including alarms and errors, will appear at the top of the **Dashboard**. The timestamp of the most recent occurrence will also be listed.

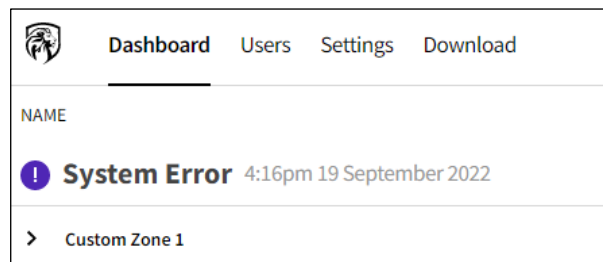
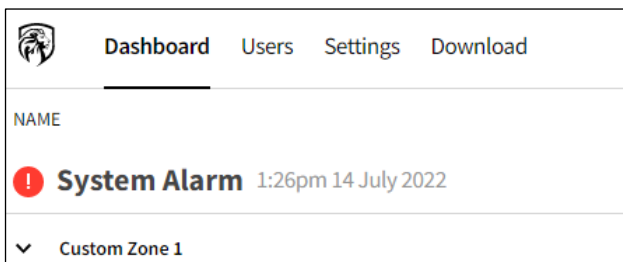

System error notifications can also be selected to show more detailed error codes that are currently present. See section 4.3.2 for a full list of error codes and troubleshooting guidelines.

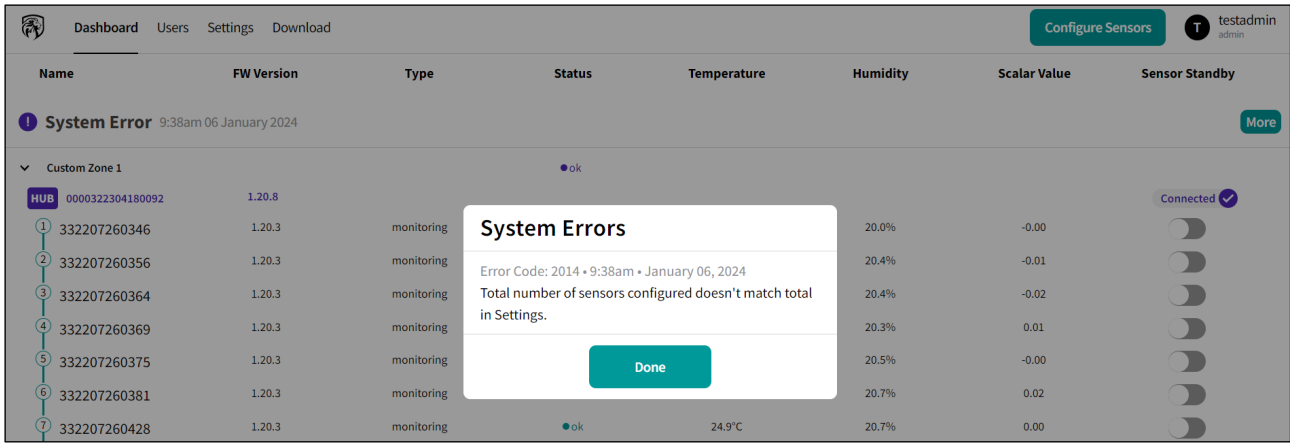

4.2.4.1 Sensor Naming

One additional feature of the **Dashboard** is the sensor naming tool. When hovering the cursor over the sensor's serial number, an edit icon will appear which allows sensor naming. The sensor names are used in the relay mapping table (*section 4.2.6.2*) and Modbus mapping tool (*section 4.2.3.2*). It is recommended to name sensors to help map them to their physical location in the system and configure the outputs.

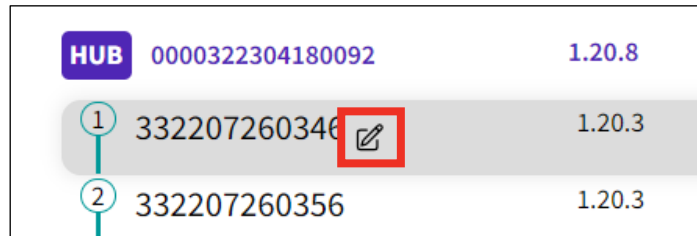

Once sensors have been renamed, the serial number will be listed under the names, as shown below:

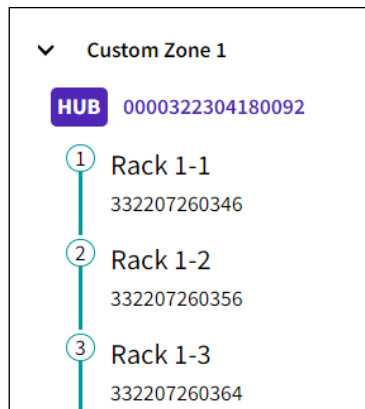

4.2.4.2 Sensor Standby Mode

Another feature of the **Dashboard** is the sensor standby mode toggles. When toggled ON, alarms from the toggled sensor(s) will be disabled. This is helpful when performing cleaning or other procedures around the Li-ion Tamer system to nullify potential nuisance alarms.

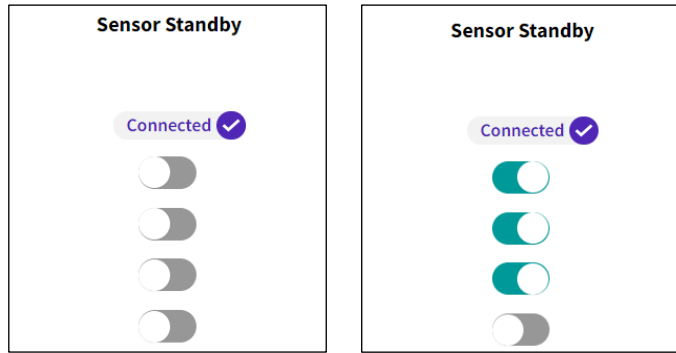

Note!

The standby mode toggles **do not automatically turn OFF**. It is critical to make sure all sensor standby mode toggles are manually turned OFF before leaving a system for continuous operation.

4.2.5 Users Tab

The **Users** tab is used to add and remove registered users from the system. Only users with the role of “admin” may access and modify the **Users** tab. The page appears as shown below:

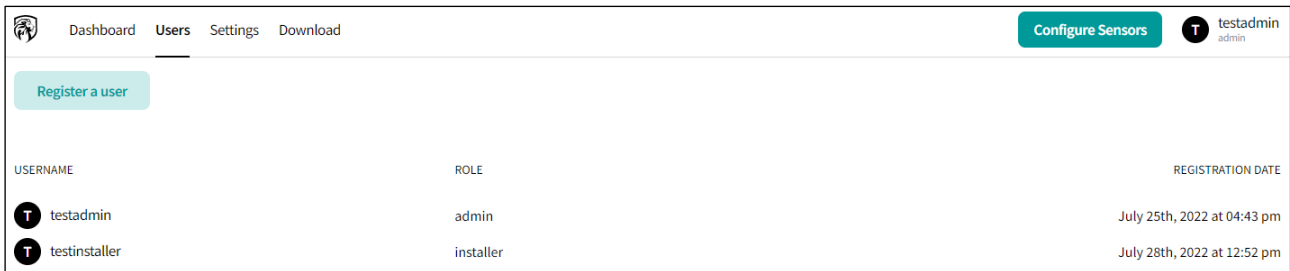

The page displays all registered users, for each one the username, role, and registration date appear.

To add a new user, follow these steps:

1. Click “Register a user”, the following pop-up appears:

Register a user

Username
username

Role
Admin

Password
password

Repeat password
repeat password

Cancel Register user

2. Enter the username.
3. Select the user’s role.
4. Enter the password and confirm it.
5. Click “Register user”. The newly created user will now populate in the list of users.

To remove a user, follow these steps:

1. Click the username, a sidebar is opened as shown below:

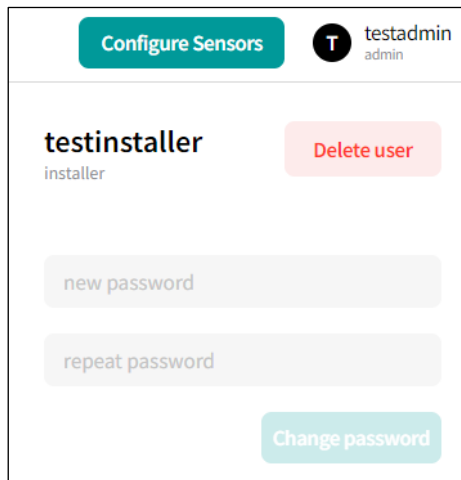

2. Click “Delete user” and follow the prompts to confirm the deletion, the removed user will no longer appear in the list of users. If it’s the only registered admin user, you cannot delete it since there must always be at least one “admin” user registered to a controller.

To change the user’s password, follow these steps:

1. Click the username.
2. Enter the new password and confirm it.
3. Click “Change password”.

4.2.6 Settings Tab

The **Settings** tab is used to configure the overall system settings, such as the number of sensors, zones and the types of outputs being used.

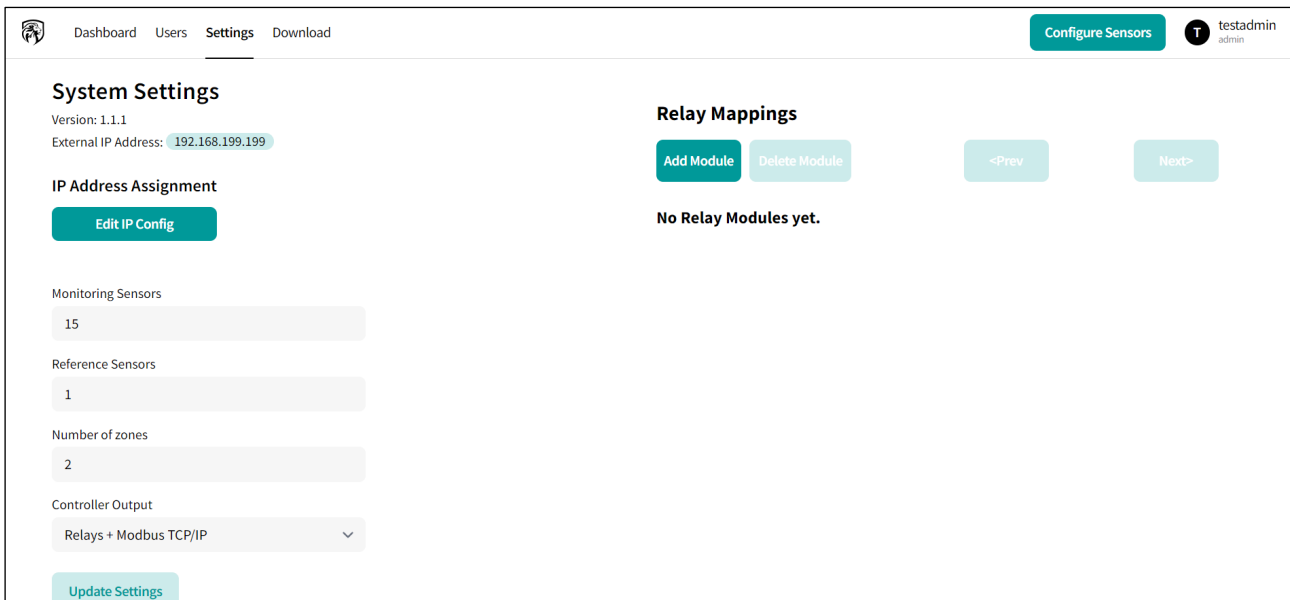

The page is divided into two parts: the left one contains the system settings, including the software version, external IP address, IP Address Assignment tool (*section 4.2.6.1*), quantities of each sensor type, quantity of zones, and the type of output(s) being used. As for the right side, it displays the relay mapping table (*section 4.2.6.2*).

To change any of the system settings, simply modify the values then click “Update Settings”. If the change is successful, the following pop-up appears at the bottom right corner of the window.

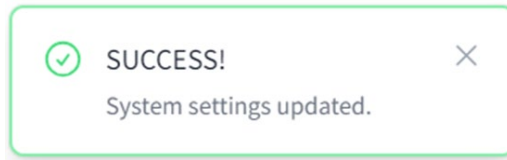

4.2.6.1 IP Address Assignment Tool

The Network 2 port, which is exclusively for the Modbus TCP/IP output signal, can have its static IP address changed for ease of integrating with other networks.

To change the IP address, follow these steps:

1. Click "Edit IP Config".

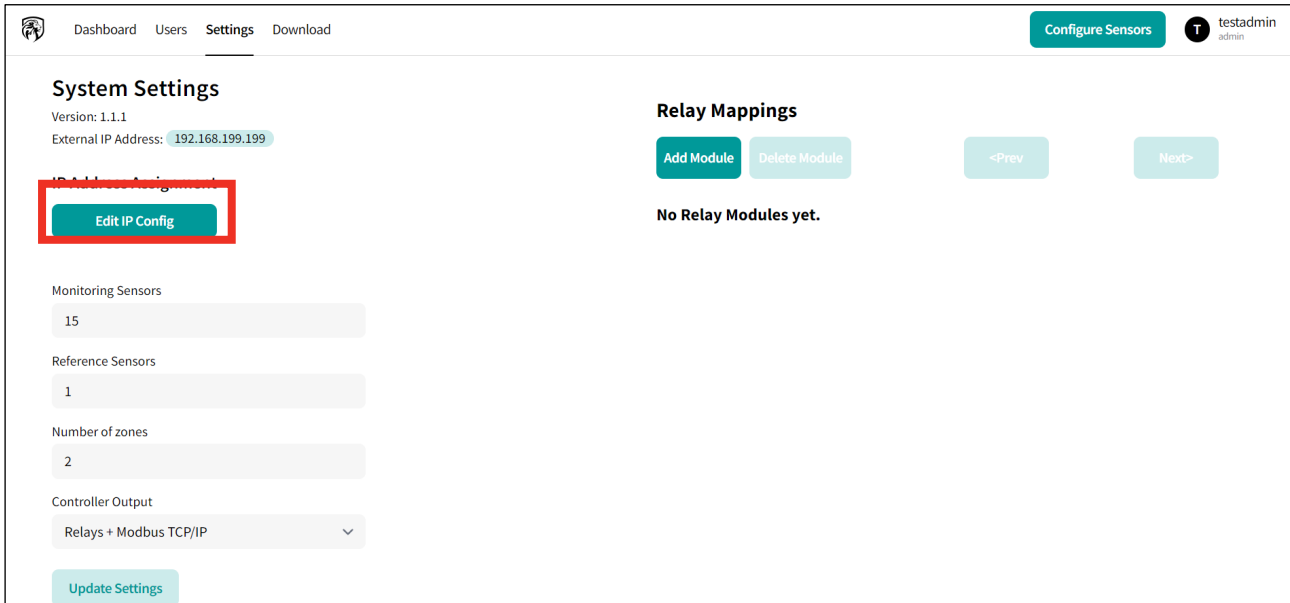

2. Select an IP version (IPv4 or IPv6).

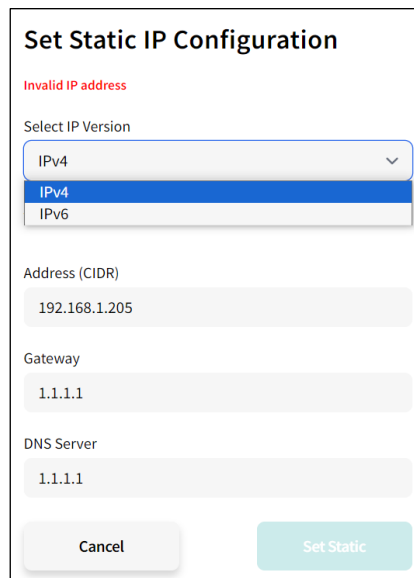

3. Enter the IP address in CIDR format.
4. Enter the gateway.
If there is no physical gateway, the gateway may be arbitrary but should not conflict with any other IP addresses on the network.
5. Enter the DNS server.
Typically, this can be 8.8.8.8 or 1.1.1.1 if no specific DNS server is being used.

6. Click "Set Static".

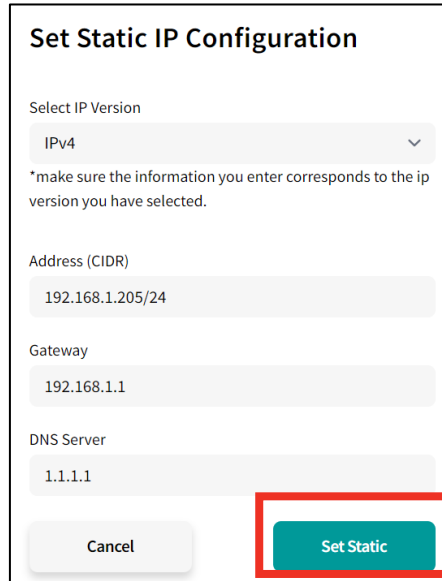

7. The pop-up shown below will appear and remain on-screen for 10 minutes.

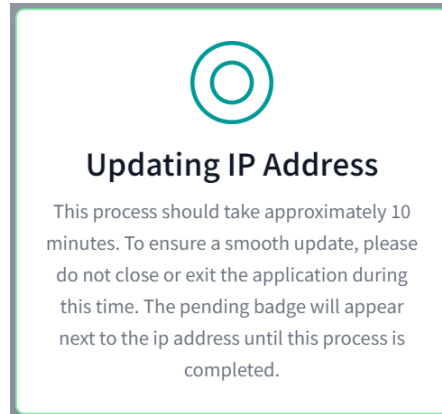

If the pop-up lasts for longer than 10 minutes, then the computer lost connection with the controller during the update process. Power-cycle the controller, reconnect to the software interface, and repeat Steps 1-7 if the External IP Address has not been changed.

4.2.6.2 Relay Mapping Table

The relay mapping table is used to assign output signals to relay positions and configure whether they are normally energized/ de-energized or latching/ non-latching. Additionally, more relay modules can be added to the system by selecting "Add Module". Note that the additional relay modules must be configured with the proper ADDR (see Section 3.2.1).

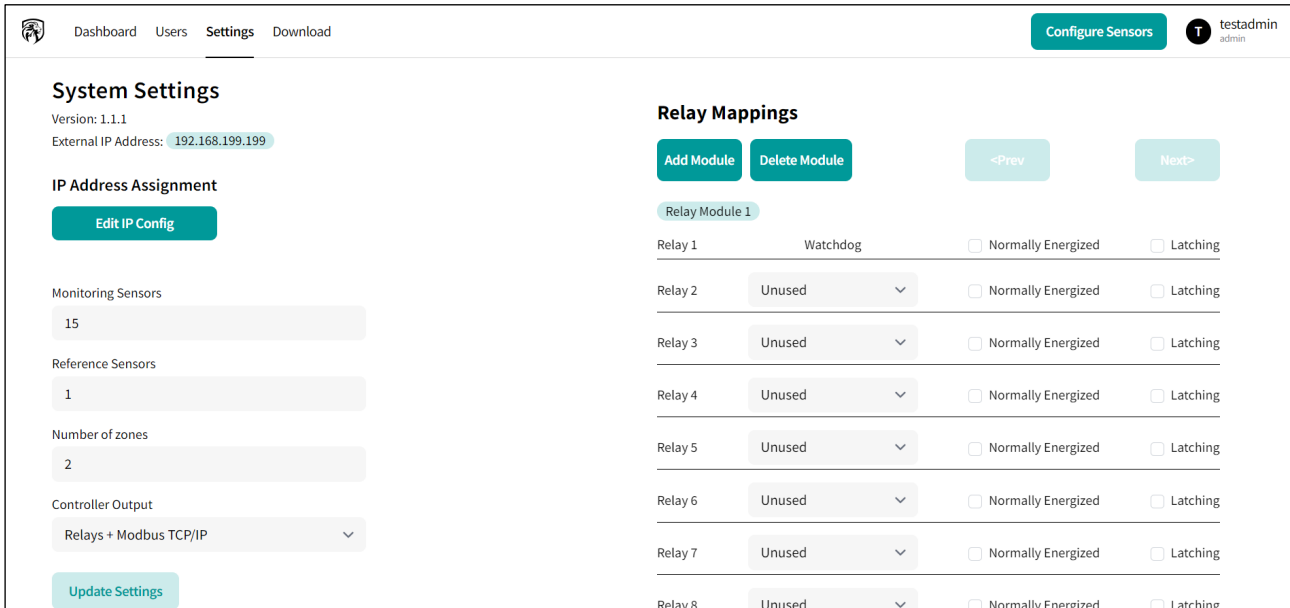

To configure a relay contact, follow these steps:

1. Select the drop-down menu for one of the relay positions (2 through 16).
If using individual sensor alarms and errors for the relays, it is recommended to name sensors first (section 4.2.4.1). Sensors that are not named will be listed by their Sensor ID, which is a unique number attributed to each sensor serial number.

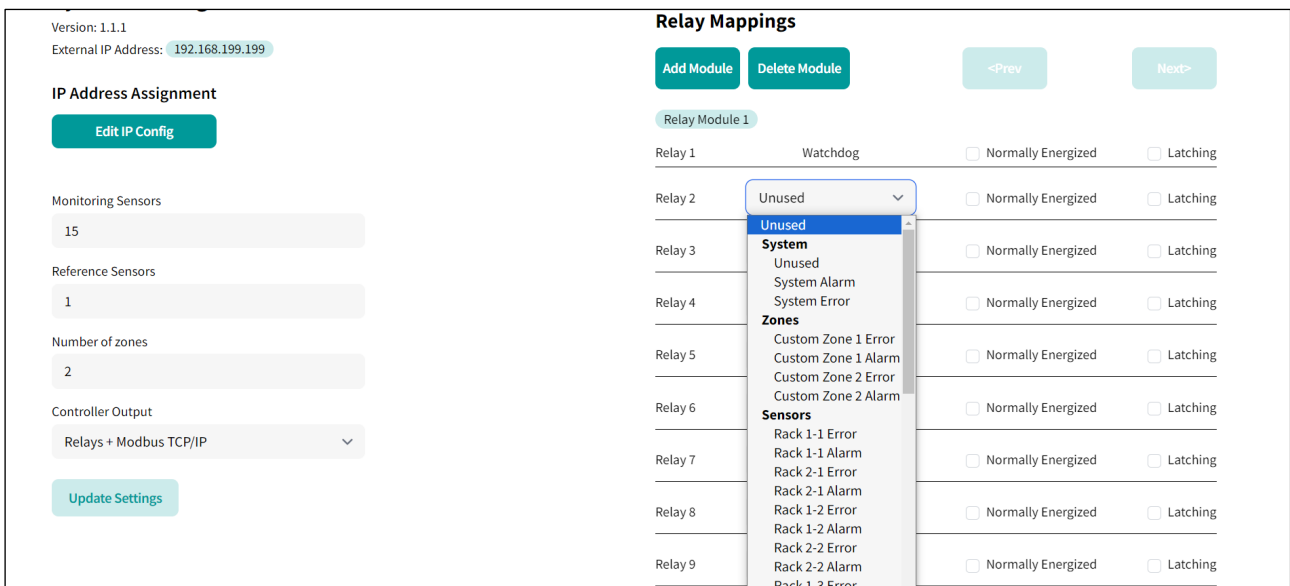

2. Select the signal to be used for the relay contact.
There are options for System Alarm, System Error, Zone Alarm(s), Zone Error(s), Individual Sensor Alarm(s), and Individual Sensor Error(s).
3. To set the relay contact as normally energized, select the "Normally Energized" checkbox.
A normally energized relay will have default connection between the common (C) and normally open (NO) contacts.

Relay	Signal	Normally Energized	Latching
Relay 1	Watchdog	<input type="checkbox"/>	<input type="checkbox"/>
Relay 2	System Alarm	<input checked="" type="checkbox"/>	<input checked="" type="checkbox"/>
Relay 3	System Error	<input checked="" type="checkbox"/>	<input type="checkbox"/>
Relay 4	Custom Zone 1 Ala...	<input type="checkbox"/>	<input checked="" type="checkbox"/>
Relay 5	Custom Zone 1 Error	<input checked="" type="checkbox"/>	<input type="checkbox"/>
Relay 6	Custom Zone 2 Ala...	<input type="checkbox"/>	<input checked="" type="checkbox"/>
Relay 7	Custom Zone 2 Error	<input checked="" type="checkbox"/>	<input type="checkbox"/>

- 4. To set the relay contact as latching, select the “Latching” checkbox.
 - A latching relay will lock the relay contacts after activation of the respective signal.
 - To unlatch, enter the software user interface and either toggle the “Latching” checkbox or select the “Unlatch Relays” button at the bottom of the page.

Relay 15	Unused	<input type="checkbox"/>	Normally Energized	<input type="checkbox"/>	Latching
Relay 16	Unused	<input type="checkbox"/>	Normally Energized	<input type="checkbox"/>	Latching

Unlatch Relays

4.2.7 Download Tab

The **Download** tab is used to access the event log and raw data from the controller.

Dashboard Users Settings **Download**

Download Data

Start Date and Time (in UTC) End Date and Time (in UTC)

mm/dd/yyyy --:-- -- mm/dd/yyyy --:-- --

*leave blank for all

EVENT LOG

View Recent Events **Download Event Log**

RAW DATA

Password

Password

Download Raw Data

SENSOR MAP

Download Sensor Map

There are several options for viewing or downloading the event log:

- **View Recent Events:** when clicking it a pop-up appears displaying the most recently logged events, starting with the most recent.

Recent Events		
EVENT	DATE	TYPE
Code: 2015	7/28/2022, 12:36:42 PM	config_error
Number of sensors configured with zone does not match zone settings. Edit zone or add/remove sensors.		
Code: 2002	7/28/2022, 12:36:33 PM	sensor
New sensor connected.		
Code: 2002	7/28/2022, 12:36:33 PM	sensor
New sensor connected.		

- **Download Event Log:** download the entire event log by clicking “Download Event Log”. This will download a .csv file containing all events that have been logged on the controller since the start of operation. To only download a portion of the event log, input a start and end date/ time in UTC time zone.
- **Download Raw Data:** this download is password-protected and may only be accessed by users authorised by Xtralis. Clicking this button will download a .csv file containing the time-series database.

Another feature of the **Download** tab is the sensor map download. The sensor map download button generates a .csv file containing a list of all sensors that have been logged with the controller, along with their internal sensor IDs, serial numbers, status, and name.

SENSOR MAP

Download Sensor Map

	A	B	C	D
1	id	serial	state	name
2	1	332207260346	Active	Rack 1-1
3	2	332207260356	Active	Rack 1-2
4	3	332207260364	Active	Rack 1-3
5	4	332207260369	Active	Rack 1-4
6	5	332207260375	Active	Rack 1-5
7	6	332207260381	Active	Rack 1-6
8	7	332207260428	Active	Rack 1-7
9	8	332207260441	Active	Rack 1-8
10	9	332207260443	Active	Rack 1-9
11	10	332207260455	Active	Rack 1-10
12	11	332207110026	Active	Rack 2-1
13	12	332207110031	Active	Rack 2-2
14	13	332207110033	Active	Rack 2-3
15	14	332207110037	Active	Rack 2-4
16	15	332207110038	Active	Rack 2-5
17	16	342207110098	Active	Reference 1

4.3 System Commissioning

Once the system has been properly configured in the **Configure Sensors** screen, follow the commissioning steps below:

1. Navigate to the **Dashboard** (see section 4.2.4 for more details).

If there are any errors present, they are indicated by “System Error” message shown below:

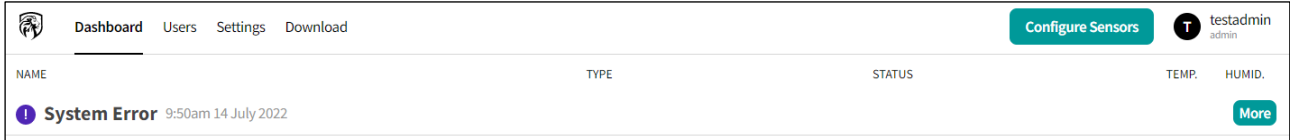

2. Click the error icon to view the active error codes.
3. Resolve any errors before proceeding.
See section 4.3.2 for a list of error codes and troubleshooting steps.
4. Confirm proper earth grounding of the hubs.
 - Use a multimeter or an equivalent device to check the effectiveness of the connectivity between the different parts of the installed equipment to the ESS ground.
 - Measure earth ground resistance between the following locations for each hub in the system and record in the Commissioning Sheet (Doc. No. 37148):
 - Power supply earth ground to hub output cable RJ45 plug (on metal connector shell) at Ethernet switch or controller.
 - Using IEEE Std 142-2007 “Recommended Practice for Grounding” and IEEE Std 1100-2005 “Recommended Practice for Powering and Grounding Electronic Equipment”, the ideal grounding value would be less than 1Ω from the equipment into the earth.
 - Recommend ground resistance measurements for Li-ion Tamer are less than 25Ω from the hub output cable to ESS earth ground.
5. Gas bump test each sensor (see section 4.3.1 for details).
 - The sensor LED indicator can be used to confirm sensor responses (see section 2.5.3).
 - The **Dashboard** can also be used to confirm sensor responses, as shown below, with the individual sensor, zone and system level alarm indicators.

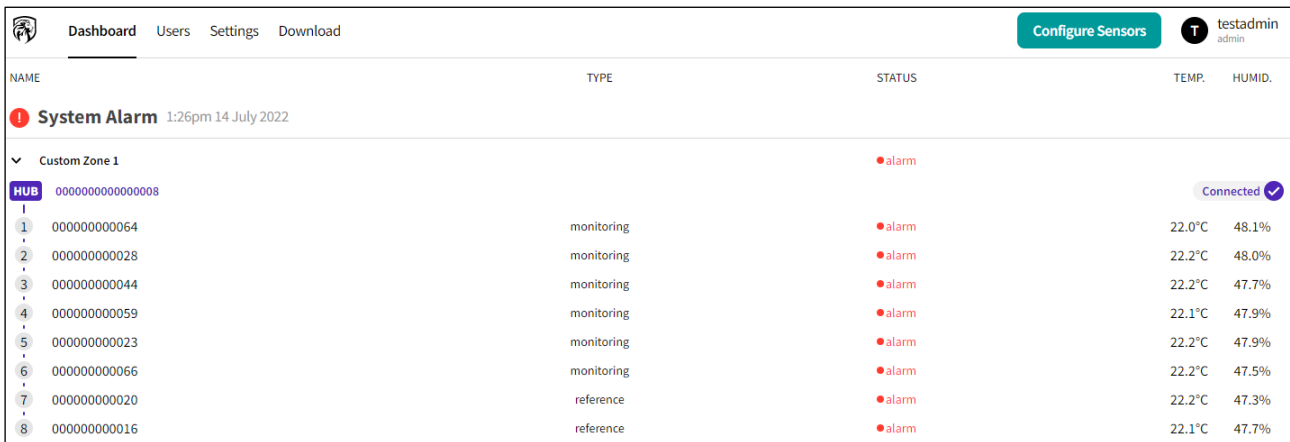

- If the relay output option is being used, confirm that the zone and system level alarm relays trigger appropriately.
6. Simulate a sensor error by disconnecting a terminator from at least one sensor chain in each zone.
 - The sensor LED indicator can be used to confirm sensor responses (see section 2.5.3).
 - The **Dashboard** can also be used to confirm sensor responses, as shown below, with the individual sensor, zone and system level error indicators.

NAME	TYPE	STATUS	TEMP.	HUMID.
System Error 1:37pm 14 July 2022 More				
Custom Zone 1		error		
HUB 0000000000000008				Error connecting ✖
1 0000000000000064	monitoring	unplugged	22.1°C	46.6%
2 0000000000000028	monitoring	unplugged	22.2°C	46.6%
3 0000000000000044	monitoring	unplugged	22.3°C	46.1%
4 0000000000000059	monitoring	unplugged	22.2°C	46.1%
5 0000000000000023	monitoring	unplugged	22.3°C	46.0%
6 0000000000000066	monitoring	unplugged	22.7°C	44.8%
7 0000000000000020	reference	unplugged	22.3°C	45.4%
8 0000000000000016	reference	unplugged	22.1°C	46.0%

- If the relay output option is being used, confirm that the zone and system level error relays trigger appropriately.
7. Navigate to the **Download** tab to download the event log for commissioning records. See section 4.2.7 for more information on the **Download** tab.
- Click “Download Event Log” to download the controller’s time-stamped event log as a .csv file. It is recommended to rename the file using an appropriate controller or project identifier.
 - To limit the event log file, input the start and end date/ time in UTC time zone.

Dashboard Users Settings **Download**

Download Data

Start Date and Time (in UTC) End Date and Time (in UTC)

mm/dd/yyyy --:-- -- mm/dd/yyyy --:-- --

*leave blank for all

EVENT LOG

View Recent Events
Download Event Log

4.3.1 Bump Test Procedure

The Li-ion Tamer DEC Test Bottle (LT-ACC-TST) may be provided by Xtralis upon request. The small bottle is filled with a small amount of diethyl carbonate to be used for bump testing of sensors. This liquid must be safely transferred into the larger puff-test bottle prior to testing the sensors. Follow the procedure below to correctly test sensors.



Note!

Use proper personal protective equipment when transferring liquid between bottles. It is important that the puff-test bottle never be turned up-side down during use and is not intended to be refilled.

Required Materials for Testing:

- Li-ion Tamer DEC Test Bottle
- Latex gloves (recommended)
- Safety glasses (recommended)

How to Use:

1. Position the bottle relative to the desired sensor, as shown in the below example:



2. Open the tab on the cap.
3. Firmly squeeze the bottle to release a puff of headspace gas towards the sensor face.
WARNING: Avoid ejecting liquid from the bottle, especially onto the sensor. If the sensors were recently powered on, wait at least 30 minutes prior to testing.
4. Proceed to bump test all sensors, close the tab on the cap and observe the sensors' responses.



Note!

If the test liquid is being shipped, transfer the liquid back into the small, leak-proof bottle.

To maximize the test liquid lifetime, store it in the small bottle.

4.3.2 Error Handling and Diagnostics

The following table details potential system error codes, which will appear on the **Dashboard**, and their corresponding diagnostic indicators. Error codes generated by the Hubs or Sensors are 3-digits, while internal error codes for the Controller are 4-digits. See section 2.5.3 for more details on the hub and sensor LED indicators.

Error Code	Error Condition	Other Diagnostic	Troubleshooting/ Resolution Steps
103	+12 V Power Supply Voltage Low at Hub	<ul style="list-style-type: none"> • Affected Sensor(s) and Hub LED Blip Green • Dashboard: Hub Error Connecting, Sensor and Zone Errors present • System will continue to operate, but there may be issues with the affected Sensor(s) and Hub • Note: Error code 201 will be present simultaneously 	Hub, Direct Power: <ol style="list-style-type: none"> 1. Check supply voltage to the affected Hub 2. Rewire as necessary Hub, PoE: <ol style="list-style-type: none"> 1. Check cable continuity and resistance between Hub and PoE Switch – replace non-conforming cables 2. Replace affected Hub

Error Code	Error Condition	Other Diagnostic	Troubleshooting/ Resolution Steps
104	+ 3.3 V Power Supply Voltage Low at Hub	<ul style="list-style-type: none"> Dashboard: Sensor and Zone Errors present System will continue to operate, but there may be issues with the affected Sensor(s) and Hub 	1. Replace affected Hub
106	Excess Sensors on Chain A	<ul style="list-style-type: none"> Excess Sensor(s) LED Fast Flash Yellow Excess Sensor(s) may not power on, if Hub power supply capacity is exceeded Affected Hub LED Fast Flash Yellow Dashboard: Hub Error Connecting, excess Sensor(s) will not appear 	1. Check Sensor quantity on affected Hub chain A and remove any excess Sensors
107	Excess Sensors on Chain B	<ul style="list-style-type: none"> Excess Sensor(s) LED Fast Flash Yellow Excess Sensor(s) may not power on, if Hub power supply capacity is exceeded Affected Hub LED Fast Flash Yellow Dashboard: Hub Error Connecting, excess Sensor(s) will not appear 	1. Check Sensor quantity on affected Hub chain B and remove any excess Sensors
108	Excess Sensors on Hub	<ul style="list-style-type: none"> Excess Sensor(s) may not power on, if Hub power supply capacity is exceeded Affected Hub LED Fast Flash Yellow Dashboard: Hub Error Connecting, excess Sensor(s) will not properly register (i.e. no temperature or RH% readings) 	1. Check Sensor quantity on affected Hub and remove any excess Sensors
109	Hub Reboot	<ul style="list-style-type: none"> Affected Hub and Sensor(s) LED Slow Flash Blue while rebooting System will continue to operate with remaining Hubs and Sensors If a Hub repeatedly reboots during normal operation, it should be addressed 	1. Replace any Hub that is experiencing repeated reboots
110	Hub Memory Corruption	<ul style="list-style-type: none"> Affected Hub will not operate properly 	1. Replace affected Hub
111	No Devices Found	<ul style="list-style-type: none"> Sensors on affected chain LED Fast Flash Yellow Affected Hub LED Blip Green System will continue to operate with remaining hubs and sensors 	<ol style="list-style-type: none"> 1. Check affected Hub to identify the affected chain(s) 2. Check all cable connections and continuity on the affected chain(s) 3. Add/ replace the Terminator on the affected chain
200	Gas Sensor Error	<ul style="list-style-type: none"> Affected Sensor LED Fast Flash Yellow 	1. Replace affected sensor

Error Code	Error Condition	Other Diagnostic	Troubleshooting/ Resolution Steps
		<ul style="list-style-type: none"> • Hub with affected Sensor LED Slow Flash Yellow • System will continue to operate with remaining sensors 	
201	+12 V Power Supply Voltage Low at Sensor	<ul style="list-style-type: none"> • Affected Sensor(s) and Hub LED Green Blip • Dashboard: Sensor and Zone Errors present • System will continue to operate but there may be issues with the affected Sensor(s) and Hub 	<ol style="list-style-type: none"> 1. Check cable continuity and resistance between Hub and affected Sensor(s) and confirm they are straight-through – replace non-conforming cables 2. Replace affected Sensor 3. Replace affected Hub
202	+3.3 V Power Supply Voltage Low at Sensor	<ul style="list-style-type: none"> • Dashboard: Sensor and Zone Errors present • System will continue to operate, but there may be issues with the affected Sensor(s) and Hub 	<ol style="list-style-type: none"> 1. Replace affected Sensor
203	Sensor Reboot	<ul style="list-style-type: none"> • Affected Sensor LED Slow Flash Blue as it reconnects to the Hub • System will continue to operate with remaining sensors • If a Sensor repeatedly reboots during normal operation, it should be addressed 	<ol style="list-style-type: none"> 1. Replace any Sensor that is experiencing repeated reboots
204	Sensor Memory Corruption	<ul style="list-style-type: none"> • Affected Sensor will not operate properly 	<ol style="list-style-type: none"> 1. Replace affected Sensor
205	Humidity-Temperature Sensor Error	<ul style="list-style-type: none"> • Affected Sensor LED Fast Flash Yellow • Hub with affected Sensor LED Slow Flash Yellow • System will continue to operate with remaining sensors 	<ol style="list-style-type: none"> 1. Replace affected sensor
207	Hub CAN Comm's Error with One or More Sensors	<ul style="list-style-type: none"> • Affected Sensor LED Fast Flash Yellow • Hub with affected Sensor LED Slow Flash Yellow • System will continue to operate with remaining hubs and sensors 	<ol style="list-style-type: none"> 1. Check cable continuity between Hub and affected Sensor(s) and confirm they are straight-through – replace any cables that fail continuity check 2. Replace affected Sensor(s) 3. Replace affected Hub
2006	Monitoring Sensor Disconnected when not in Configuration Mode	<ul style="list-style-type: none"> • Affected Sensor(s) may LED Fast Flash Yellow or Slow Flash Blue if attempting to reconnect • Dashboard: Sensor inactive and Zone Error present 	<ol style="list-style-type: none"> 1. If all Sensors on a chain are affected, follow steps for Error 111 2. Enter Configuration Mode, select the affected Zone, and reconnect the affected Sensor 3. Replace affected Sensor(s) that repeatedly self-disconnect

Error Code	Error Condition	Other Diagnostic	Troubleshooting/ Resolution Steps
2007	Reference Sensor Disconnected when not in Configuration Mode	<ul style="list-style-type: none"> • Affected Sensor(s) may LED Fast Flash Yellow or Slow Flash Blue if attempting to reconnect • Dashboard: Sensor inactive and Zone Error present 	<ol style="list-style-type: none"> 1. If all Sensors on a chain are affected, follow steps for Error 111 2. Enter Configuration Mode, select the affected Zone, and reconnect the affected Sensor 3. Replace affected Sensor(s) that repeatedly self-disconnect
2014	Misconfigured System	<ul style="list-style-type: none"> • Total number of sensors configured does not match the total in Settings Tab 	<ol style="list-style-type: none"> 1. Confirm correct total quantity of each sensor type 2. Either correct the values in Settings Tab or enter Configuration Mode and add/remove Sensor(s)
2015	Misconfigured Zone	<ul style="list-style-type: none"> • Total number of sensors configured in a Zone do not match the Zone settings 	<ol style="list-style-type: none"> 1. Confirm correct total quantity of each sensor type in the Zone 2. Either correct the values in Zone settings or enter Configuration Mode and add/remove Sensor(s)
7004	Hub Disconnected when not in Configuration Mode	<ul style="list-style-type: none"> • Affected Sensor(s) and Hub may LED Fast Flash Yellow or Slow Flash Blue if attempting to reconnect • Dashboard: Sensor(s) and Hub inactive and Zone Error present 	<ol style="list-style-type: none"> 1. Check all cable connections and continuity on the affected chain(s) 2. Enter Configuration Mode, select the affected Zone, and reconnect the affected Hub 3. Replace affected Hub(s) that repeatedly self-disconnect

4.4 Maintenance and Service

4.4.1 Maintenance Tests

The Li-ion Tamer GEN 3 system requires minimal operation and maintenance procedures as the off-gas monitors are designed to be calibration-free and have comparable lifetime to that of the ESS battery system. The general procedure is detailed below and should be performed annually.

1. Immediately attend to any errors generated by the system's self-diagnostics (*detailed in section 4.3.2*).
2. Perform a visual inspection.
 - Confirm that all sensor and hub LEDs are blinking Green, indicating normal operation.
 - Inspect for physical damage to controller, sensor network, cabling, sensor placement, or other visual changes to the original system construction.
 - Inspect sensors and hubs for excessive dust build up on their exteriors. Dust should be removed, especially any obstructing the pre-cut vents on the end plates, as a best practice.

**Note!**

Do not use compressed air dusters as they can alarm and potentially damage sensors.

- Ensure that all hardware has remained securely mounted.
3. Bump test the sensors to verify gas response.
 - The sensors can be activated with a bottle of battery off-gassing compounds (LT-ACC-TST), which is supplied by Xtralis.
 - Note that the bump test kit does not simulate the amount of gas released during an off-gas event. It should only be used to release gas into the head of the gas monitor for the purpose of confirming operation of the gas sensor. It should not be used to release off-gas compounds into the rack or general vicinity to see if a nearby off-gas monitor detects it.
 - When using the bump test kit care needs to be taken not to activate a reference sensor.
 - Bump test kits should be used according to instructions in *section 4.3.1*.

4.4.2 Spare Parts

Spare parts may be provided by Xtralis upon request.

4.4.3 System Decommissioning

Contact Xtralis representative for guidance on how to decommission the Li-ion Tamer GEN 3 system.

5 Frequently Asked Questions

1. What are the stages of Lithium-ion battery failure?

- Stage 1: Abuse
 - Electrical (over-charge/discharge, or internal manufacturing defects).
 - Thermal (external heating or operating the battery outside its specified temperature).
 - Mechanical (physical damage to the cell).
- Stage 2: Initial cell venting (off-gas event)
 - The battery electrolyte will convert to gas increasing the internal pressure and venting to the outside through pressure relief vent or rupture. This gas release is distinctly different than the release of gases at thermal runaway and often occurs several minutes prior to thermal runaway.
- Stage 3: Thermal Runaway
 - With increasing internal battery pressure and temperature, the separator will melt down and rupture, releasing smoke and potentially igniting the electrolyte solvent. Thermal runaway enables propagation of abuse and failure to adjacent cells, with any resulting fire further increasing the risk.

2. What is the Li-ion Tamer GEN 3 system?

- The Li-ion Tamer GEN 3 system is an advanced lithium-ion battery off-gas detection system that provides early detection of ongoing battery abuse across a wide range of battery storage environments (modular, containerized, large scale). It also includes distributed temperature and humidity sensing, increased sensor counts per controller, and improved event storage capabilities.

3. What gases does Li-ion Tamer detect?

- Li-ion Tamer is designed to respond to volatile organic compounds (VOCs) which are emitted during a lithium-ion battery off-gas event that occurs prior to thermal runaway. The initial off-gas event consists of primarily battery electrolyte solvent vapours.
- The off-gas event may also be referred to as the initial cell venting and is defined as the event in which the cell case vents due to a rise in the internal pressure of the cell.
- Li-ion Tamer will also detect the composition of gases (CO, H₂, hydrocarbons, etc.), released at thermal runaway.

4. Does Li-ion Tamer detect the initial cell venting of different Lithium-ion Chemistries?

- Lithium-ion battery chemistry refers to anode and cathode chemistry, such as LFP (Lithium Ferro-Phosphate or lithium iron phosphate) or NMC (Nickel Manganese Cobalt).
- Yes, Li-ion Tamer can detect the initial cell venting (off-gassing) of different lithium-ion battery chemistries. It does this by detecting the presence of battery electrolyte solvent vapours which are common to all battery chemistries. It is agnostic towards the types of anode and cathode chemistries used.

5. How do you stop thermal runaway?

- Li-ion Tamer can detect off-gassing of different lithium-ion battery chemistries; it does this by detecting the presence of battery electrolyte solvent vapours which are common to all batteries.
- The off-gas event, or cell venting, is a distinct stage in the stages of a battery failure which occurs prior to the onset of thermal runaway for most forms of battery abuse.
- Off-gas events are the earliest indicator of thermal runaway and once detected provides sufficient time to initiate containment measures, such as automatically isolating the components of the ESS or otherwise placing it in a safe condition. This action provides a barrier to the onset of thermal runaway.
- Other mitigating actions can be explored based on system constraints, including increased cooling, local alarms, remote alarms and ventilation activation to remove flammable gas accumulation.

6. Don't Battery Management Systems (BMS) provide sufficient protection?

- No, despite the presence of BMSs, thermal runaway events are occurring. BMSs monitor temperature and electrical loading but these systems may have insufficient resolution or granularity at a cell level allowing an initial cell failure to occur. BMSs may also experience sensor failure.
- The Li-ion Tamer product provides an independent and reliable monitoring solution for all lithium-ion batteries and is an essential safety layer within a Failure Modes Effects Analysis (FMEA) for improving the overall safety.

7. Can Li-ion Tamer tell me where the off-gas event has occurred?

- Every Li-ion Tamer system deployed will deliver on single cell off-gas event detection, which will allow subsequent localized investigation.
- Li-ion Tamer systems can be designed to suit customer needs, whether it be maximum granularity for faster investigation, targeted mitigating action or cost effectiveness.

8. How many minutes of early warning does Li-ion Tamer provide?

- The Li-ion Tamer product typically provides between 2 and 30 minutes warning of a thermal runaway event. The severity of the abuse factor greatly affects the amount of time between the cell venting and thermal runaway.
- When using the UL 9540A recommended failure method (overheating), Li-ion Tamer consistently delivers early warning with many different types of cell manufacturers, chemistries, and form factors.

9. What is the physical arrangement of the hardware?

- The Li-ion Tamer GEN 3 system consists of a distributed sensor network that is aggregated at a Controller.
- There are two types of sensors:
 - Monitoring sensors: placed near the battery racks and monitor for off-gas events.
 - Reference sensors: distributed in potential nuisance alarm locations to increase system reliability.
- Groups of sensors are daisy-chained together and routed back to a Hub.
- Hubs provide power to all sensors connected via the daisy-chain.
- Hubs can be powered by a Power over Ethernet (PoE) Switch or by a 12VDC supply.
- Hubs are connected to an Ethernet Switch, which connects to the Controller.
- The Controller has a couple of communication protocols:
 - Modbus TCP/IP output (native to the controller)
 - Relay output (via an auxiliary relay module)

10. Can the Li-ion Tamer system be installed with less than one sensor per rack?

- Refer to the Li-ion Tamer Design Guide (Doc. 36094) for details on reducing sensor quantities and designing custom systems for applications.

11. What is the detection level?

- The Li-ion Tamer sensor has been designed to operate in a binary state, either in a normal or alarm state. This allows Li-ion Tamer to focus on the smallest presence of an off-gas event in any concentration as an abnormal condition for immediate alarm reporting.
- The proprietary event detection algorithm is also based around a rate of gas generation consistent with an off-gas event or cell venting occurring.

12. Does Li-ion Tamer meet ESS Codes and Standards?

- Li-ion Tamer meets NFPA 855 4.2.9.2 and NFPA 855 9.3.
 - NFPA 855 4.2.9.2
The Energy Storage Management System (ESMS) shall electrically isolate the components of the ESS or place it in a safe condition if potentially hazardous temperatures or other hazardous conditions are detected.
Li-ion Tamer helps meet this by detecting hazardous conditions other than temperature.
 - NFPA 855 9.3
Thermal Runaway Protection. Where required by Table 9.2, a listed device or other approved method shall be provided to preclude, detect, and minimize the impact of thermal runaway.
Li-ion Tamer helps detect events that preclude thermal runaway (i.e. the initial cell venting) as well as being able to detect the gases released by thermal runaway.
 - NFPA 69 8.3.1
Combustible Concentration Limit. The combustible concentration shall be maintained at or below 25 percent of the LFL, for all foreseeable variations in operating conditions and material loadings.
Li-ion Tamer detects the presence of combustible gas mixtures and can initiate ventilation to control explosive atmospheres.
- Li-ion Tamer is CE/ UKCA marked, IEC 61010 compliant and FM 6540 approved for Battery Electrolyte Solvent Vapours (ex. DEC, DMC, EMC).

13. Is there third-party testing of Li-ion Tamer?

- Yes, the Li-ion Tamer system has been tested by many third-party entities. Li-ion Tamer participated in a joint-industry program to increase the safety of lithium-ion batteries organized by DNV-GL. DNV-GL showed in their testing that Li-ion Tamer was able to prevent thermal runaway.
(<https://www.dnvgl.com/maritime/publications/Technical-Reference-for-Li-ion-Battery-Explosion-Risk-and-Fire-Suppression-report-download.html>)
- Li-ion Tamer was tested by Energy Safety Response Group (ESRG) alongside aspirating smoke detectors and commercial gas detectors. ESRG shows in their testing that Li-ion Tamer was able to reliably provide the earliest warning of battery abuse through initial cell venting detection.
(<https://buildings.honeywell.com/content/dam/hbtbt/en/documents/downloads/li-ion-tamer/hon-ba-nexceris-2021-test-summary-report.pdf>)
- Li-ion Tamer has been implemented in UL 9540A tests to generate supplemental information for select customers.

14. How can you be sure Li-ion Tamer works in my systems' airflow?

- Li-ion Tamer has been extensively tested in many different battery environments, under varied ventilation conditions. During the applications engineering process, the ESS air flow patterns are considered to ensure the system operates within its performance envelope.
- If you have a specific battery configuration that requires off-gas detection; individual assessment or testing can be conducted. Additionally, if UL9540A testing is going to be performed, Li-ion Tamer hardware can be implemented for evaluating product functionality.

15. How do you know if the Li-ion Tamer GEN 3 system is functioning properly?

- Li-ion Tamer has multiple methods of communicating self-diagnosed error states.
- Both the sensors and hubs have LED status indicators, and all error states are communicated to the Controller for user notification.
- *Refer to the section 4.3.2 for details on the error states, as well as troubleshooting recommendations.*

16. Can the Li-ion Tamer system be tested with a test-gas to activate the off-gas monitor?

- Yes, the sensors can be activated with a bottle of battery off-gassing compounds (LT-ACC-TST), which is supplied by Xtralis.
- It should be noted that the bump test kit does not simulate the amount of gas released during an off-gas event. It should only be used to release gas into the head of the gas monitor for the purpose of confirming operation of the gas sensor. It should not be used to release off-gas compounds into the rack or general vicinity to see if a nearby off-gas monitor detects it.
- When using the bump test kit care needs to be taken not to activate a reference sensor.
- Bump test kits should be used according to instructions provided by Li-ion Tamer.
- Bump tests should only be performed by appropriately trained and qualified personnel.

17. Are all the off-gas monitors on the system interchangeable?

- Off-gas monitors with the same part number are interchangeable
- Reference (LT-SEN-R3) and Monitoring (LT-SEN-M3) Sensors are not interchangeable
- Reference and Monitoring Sensors are color-coded.

18. Can any RJ45 cable (i.e. ethernet cable) be used to connect an OGM to the controller?

- Refer to the Li-ion Tamer Engineering Specification (Doc. 37143) for details on required cable specifications.

19. How do we know the parts have not been tampered with between shipping and receipt?

- Every sensor and hub package is heat sealed in an ESD bag. If that seal is broken prior to commissioning and installation, please contact an Xtralis representative to request a replacement.