XTRALIS LI-ION TAMER GEN 2+ SENSOR-ONLY SOLUTION (ANALOGUE VOLTAGE OUTPUT) APPLICATION NOTE

Contents

1	Introduction.....	2
2	Sensor-Only Solution (Analogue Voltage Output) Wiring Requirements	2
3	Sensor-Only Solution (Analogue Voltage Output) Signal Integration	4
4	Further Support	4

Preface

This Application Note outlines how to integrate the analogue VOLTAGE output of a GEN 2+ Li-ion Tamer Monitoring Sensor (LT-SEN-M) into an existing control system, without the use of the Combined Controller (LT-CTR-C).

Related Products

Li-ion Tamer Rack Monitor Sensor (GEN 2+)

1 Introduction

The GEN 2+ Monitoring Sensor (LT-SEN-M) is typically installed as part of the Li-ion Tamer Rack Monitor (GEN 2+) system; however, there are applications that require either one or very few sensors. Other applications are space-prohibitive and adding the full Rack Monitor System is not feasible. In those cases, taking the approach of a GEN 2+ sensor-only solution with analogue voltage output may be done.

The following sections details how to properly wire and integrate the sensors in this application.

**Note!**

While this document provides details on how to properly wire a sensor-only solution, final wiring and integration should only be performed by properly trained and qualified installers.

2 Sensor-Only Solution (Analogue Voltage Output) Wiring Requirements

The GEN 2+ Monitoring Sensor has the dimensions shown in the image below:

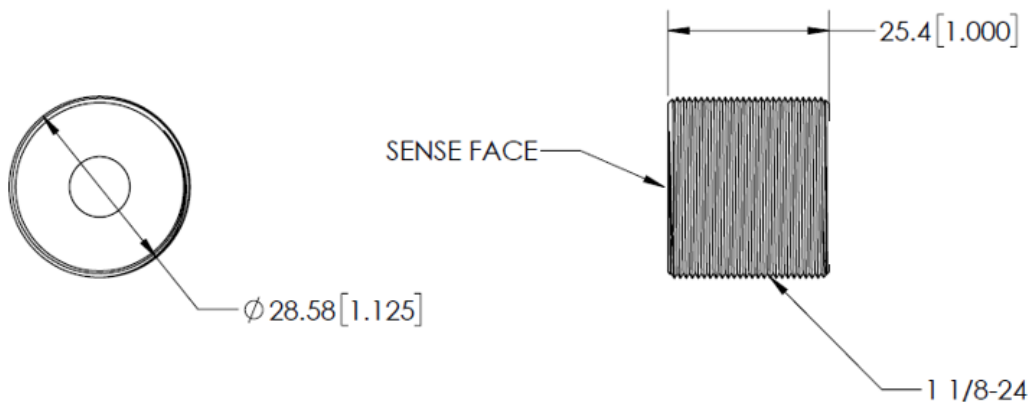

Note that each sensor is equipped with a female RJ45 connector that is built into the housing. Therefore, any cable used to integrate this sensor will require at least one end to be a male RJ45 connector.



The pinout of the sensor’s female RJ45 port is detailed below:

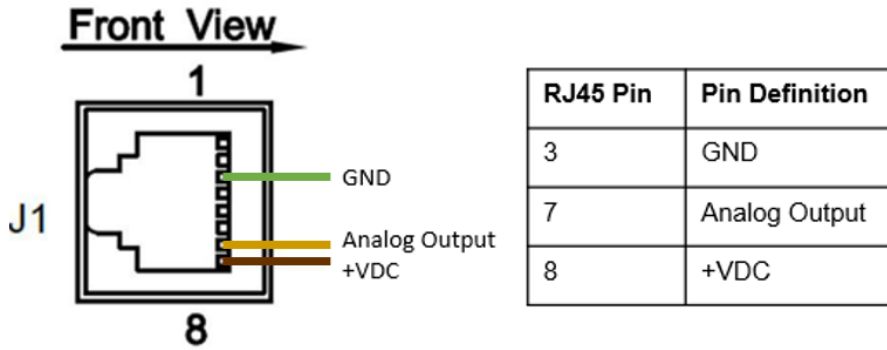

The requirements for cables used in this application are as follows:

- Must have at least one end terminated with a male RJ45 connector. Termination type on the opposite end may vary but must follow the provided pinout.
- Must be Cat 5e or Cat 6a, straight through, shielded (at least S/UTP), 24 – 28 AWG cable with shield connected to RJ45 connector shell.
- Must allow for connection of drain wire or shielding to earth GND.
- Maximum cable length 30.5m (100ft)

An example wiring diagram is shown below:

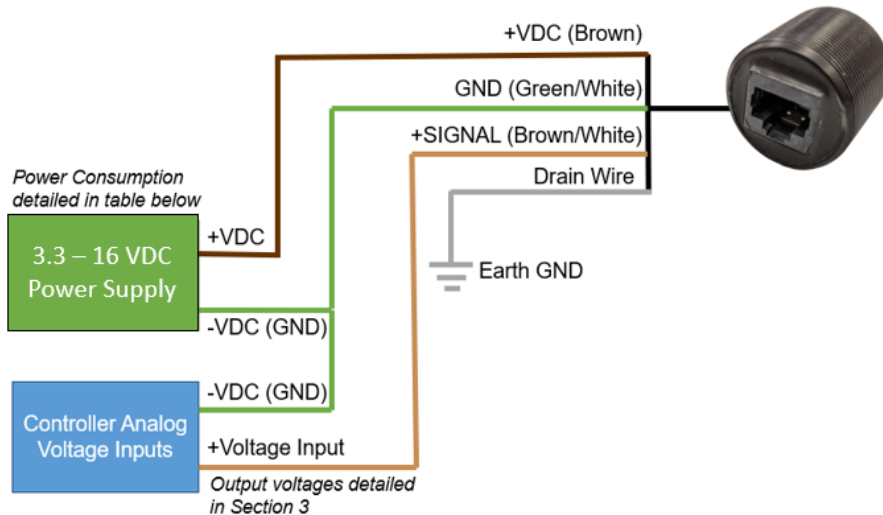

Note that the conductor color coding follows typical T568B pinout.

Power Consumption Specifications	
Sensor Power Input	3.3-16 VDC (5 VDC nominal)
Power Consumption	275 mW (@ 5 VDC and 25°C)

3 Sensor-Only Solution (Analogue Voltage Output) Signal Integration

The analog voltage output from the GEN 2+ Monitoring Sensor has several unique voltage states that it may indicate. The flow diagram below details those voltage states and how they may occur after powering the sensor on.

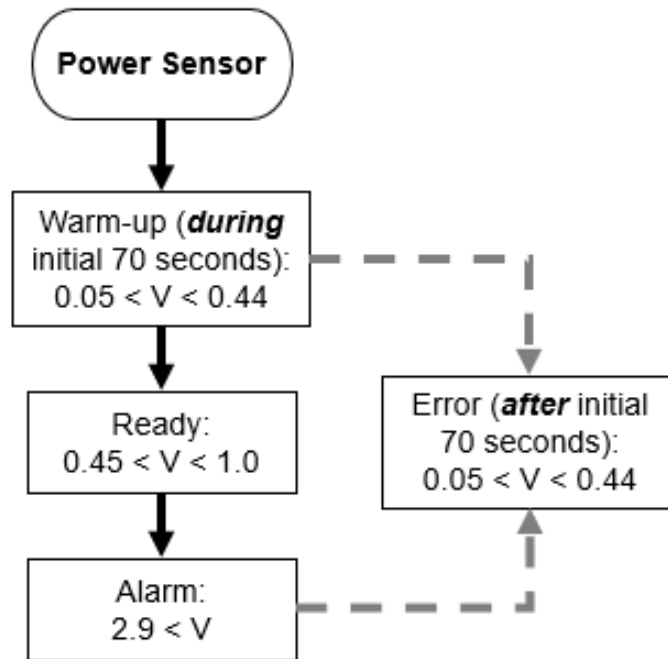

To properly integrate the sensor signal(s), the signal integration device must be capable of distinguishing, at a minimum, between the states detailed above. The voltage states above account for standard tolerances, effects of cable length, wire gauge, and power supply voltage. Note that the warm-up state may have a slight increase in voltage several seconds after powering on the sensor. This is expected and will be captured by the voltage state ranges listed above.

4 Further Support

Contact an Xtralis office or distributor for further information.