

XTRALIS VIS-IR™

FAILSAFE BI-SPECTRAL THERMOGRAPHY DETECTOR



FIRE DETECTION FOR
TOUGH ENVIRONMENTS.

- BI-SPECTRAL (VISUAL AND IR)
- EARLY FIRE DETECTION
- DIRECT CONNECTION TO FACP
- MINIMAL FALSE ALARMS
- MAXIMUM RELIABILITY

EARLY FIRE DETECTION IN CHALLENGING ENVIRONMENTS

Environments with high smoke and dust conditions as part of normal operating conditions are simply too challenging for traditional smoke and fire detectors. From waste management sites to food and drink processing plants, tough environmental conditions can make fires threats hard to detect. The same conditions can lead to frequent false alarms, resulting in disruption with loss of productivity to businesses. This is where the VIS-IR thermography detector from Xtralis can help.

VIS-IR continuously monitors heat signatures and is unaffected by challenging environmental conditions thereby providing a reliable and early warning of fire threats, and enables you to take the right action at the right time – to prevent danger, damage, disruption, and downtime.

EVERY FIRE IS DIFFERENT

In many operating environments, fire risks come in different forms and, crucially, at different temperatures.

There may be several flammable materials in one area, all with different ignition temperatures. The environment itself may be at a high or fluctuating temperature. External influences – such as the arrival of a delivery vehicle – may cause a temperature increase that can trigger a nuisance alarm.

All these factors make early detection, difficult. But the smart, failsafe, bi-spectral thermography detector Xtralis VIS-IR is designed specifically for environments and applications like these. To protect your workers, premises, and business continuity.

WHAT MAKES XTRALIS VIS-IR DIFFERENT?

Xtralis VIS-IR is a standalone edge device for early fire detection and communicates directly with FACP using on-board Pre-Alarm, Alarm and Fault relays avoiding the ever-present failure risk associated with systems that cannot perform detection on the edge.

The system is programmable to trigger pre-alarms and alarms, based on different fixed temperatures or rate of rise for different regions of interest (ROI) to suit different environments. This way, one device can monitor multiple ROIs simultaneously and only trigger an alarm when a specific area reaches its defined fixed temperature or rate of rise.

ViSM (VIS-IR Software Management) allows for configuration and continuous monitoring of the protected area. Combined with both IR and Video feed, ViSM allows the situation to be assessed remotely and safely. This visual verification capability means that situations can be analyzed more accurately so that appropriate action can be taken sooner. So, there's less danger, disruption, and downtime.

Basic System Configuration

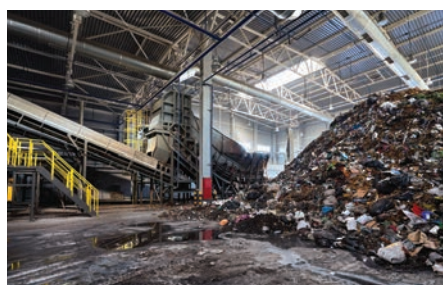
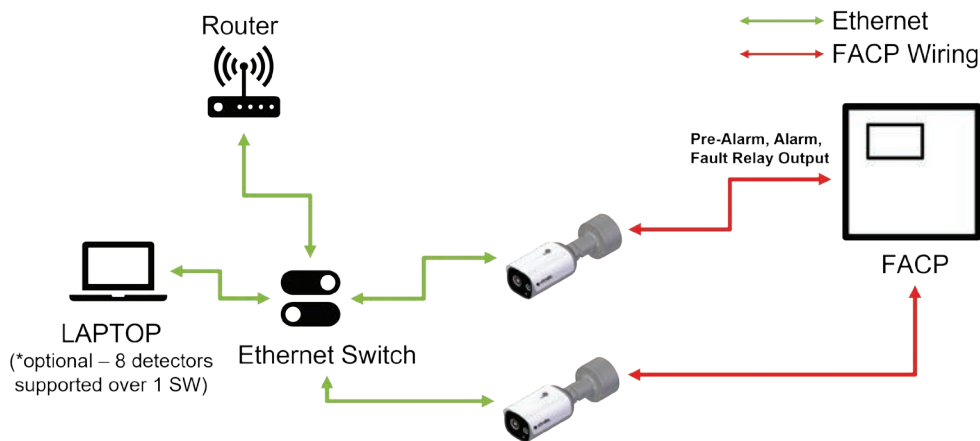

STOP FIRES BEFORE THEY TURN INTO DISRUPTION

The earlier a fire is detected, the greater the opportunity to take action to reduce the danger to life, property, and business.

Xtralis VIS-IR incorporates a range of advanced features to optimize early detection, reduce false alarms, enhance reliability, and extend the range of operating environments where it can deliver maximum protection.



Early fire detection

- Multiple alarm and pre-alarm settings with fixed temperature and Rate of Rise triggers
- Multiple Regions of Interest with individually set pre-alarms/alarms

Reliable operation

- Smart camera enabling edge configuration with direct connection to the FACP and no networked PC required
- Onboard failsafe fault relays protecting the system against any fault conditions

Real-time monitoring

- Built-in software for real-time visual verification of alarms, enabling human situational assessment and targeted response
- Recorded video allowing post-event root cause analysis and corrective actions such as configuration settings adjustments

For tough environments

- Detection temperature range of -5°C to +450°C
- IP66 certified

APPLICATIONS

Wherever traditional smoke or fire detectors fail to function effectively, Xtralis VIS-IR detects fires sooner, faster, and more reliably.

- Waste management and recycling sites
- Food and drink processing plants
- Industrial sites
- Transportation and other tunnels

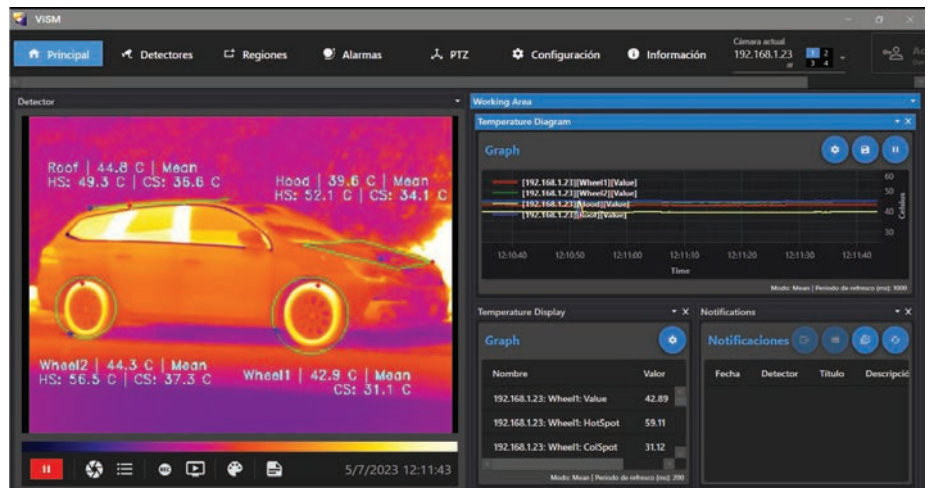

TECHNICAL SPECIFICATIONS

Specification

IR Camera	Resolution: 384x288 Accuracy: +/-2°C up to 100°C, +/-2% (100°C to 450°C) Detection Temperature Range: -5°C to 450°C NETD: <50 mK Pixel Pitch: 17 µm Frame Rate: 30 fps F Number: F# 1.2 FOV & Lenses: 22°x16°/17mm, 42x31° /8,9mm, 88°x65° /4,3mm
Visual Camera	Hardware Resolution: 2592x1944 1920x1080 (H.264) Image Sensor: 1/4" color CMOS QSXGA (5 megapixel) Light Sensitivity in Lux: 0.1 Lux
Microprocessor	IMX8M Plus
Signaling	Output Relays: 1 x Pre-Alarm, 1 x Alarm, 1 x Fault (Failsafe) LEDs: Front status LED, Remote LED output Inputs: 1 x Remote Reset, 1 x External Fault for Air Blade failure (for future use)
Video Compression	H.264
Settings	Regions of Interest: 4 Detection Area Settings: Point, line, rectangle, circle, polygon Temperature alarms/ROI: Minimum/maximum/average temperature /Rate of rise (°/minute - freely programmable) Detection: <ul style="list-style-type: none"> Hotspot & cold spot Pre-alarm, alarm Alarm delays Color Palettes: Iron (yellow=hot, blue=cold), Iron hi (yellow=hot, dark red=cold), Rainbow, Gray (black=cold), Gray (white=cold), Alarm red, Alarm blue, Alarm green, etc.
Analytics	Vehicle Discrimination, Camera Covered Fault
Supply Voltage	Supply Voltage: 24 VDC nominal Power: 24W Power over Ethernet: IEE 802.3at / 802.3af Type 2

Environmental	IP Rating: IP66 Operating Temperature: -30°C to 60°C (-22°F to 140 °F) Relative Humidity: < 90% non-condensing Weight: 1.75 kg
Communication	Micro SD Card Slot: Up to 256 GB (not included) Ethernet to Computer Management Software
Security	Signed firmware, digest authentication, password protection, secure boot, TLS encryption
Approvals	<ul style="list-style-type: none"> EMC EN61000-6-1 (2017) EMC EN61000-6-3 (2007) / A1 (2001)/AC (2012) EMC EN 50130-4 (2011) / A1 (2014) UNE-EN 62368-1:2014 + AC1:2015 + AC2:2015 EN 62368-1:2014+AC:2015+AC:2017+A11:2017 IEC 62368-1:2014+COR1:2015+COR2015 POSE000_18 FCC Rules and Regulations CFR 47, Part 15

Ordering Information

Ordering Code	Description
FTD-2216-S	Failsafe Bi-Spectral Thermography Detector FOV 22°x16°, Shutter
FTD-4231-S	Failsafe Bi-Spectral Thermography Detector FOV 42°x31°, Shutter
FTD-8865-S	Failsafe Bi-Spectral Thermography Detector FOV 88°x65°, Shutter
FTD-BB	Black Body for Maintenance Purposes

ABOUT XTRALIS



Xtralis is a leading global provider of powerful solutions for very early & reliable detection of smoke, fire, and gas threats. Our technologies prevent disasters by giving users time to respond before life, critical infrastructure or business continuity is compromised.

We protect highly valuable and irreplaceable assets and infrastructure belonging to the world's top governments and businesses.

To learn more, please visit us at www.xtralis.com