

LI-ION TAMER SENSOR MULTI OUTPUT SOLUTION (MOS) USER MANUAL



LI-ION TAMER OFF-GAS SENSOR AND INTERFACE MODULE

October 2024

Doc. No. 37924_A1

Disclaimer

The contents of this document is provided on an "as is" basis. No representation or warranty (either express or implied) is made as to the completeness, accuracy or reliability of the contents of this document. The manufacturer reserves the right to change designs or specifications without obligation and without further notice. Except as otherwise provided, all warranties, express or implied, including without limitation any implied warranties of merchantability and fitness for a particular purpose are expressly excluded.

Intellectual Property and Copyright

This document includes registered and unregistered trademarks. All trademarks displayed are the trademarks of their respective owners. Your use of this document does not constitute or create a licence or any other right to use the name and/or trademark and/or label. This document is subject to copyright owned by Xtralis. You agree not to copy, communicate to the public, adapt, distribute, transfer, sell, modify or publish any contents of this document without the express prior written consent of Xtralis.

General Warning

This product must only be installed, configured and used strictly in accordance with the General Terms and Conditions, Warranty, User Manual, Third Party Licenses, and product documents available from Xtralis website (www.xtralis.com). All proper health and safety precautions must be taken during the installation, commissioning and maintenance of the product. The system should not be connected to a power source until all the components have been installed. Proper safety precautions must be taken during tests and maintenance of the products when these are still connected to the power source. Failure to do so or tampering with the electronics inside the products can result in an electric shock causing injury or death and may cause equipment damage. Xtralis is not responsible and cannot be held accountable for any liability that may arise due to improper use of the equipment and/or failure to take proper precautions. Only persons trained through an Xtralis accredited training course can install, test and maintain the system.

Liability

You agree to install, configure and use the products strictly in accordance with the User Manual and product documents available from Xtralis.

Xtralis is not liable to you or any other person for incidental, indirect, or consequential loss, expense or damages of any kind including without limitation, loss of business, loss of profits or loss of data arising out of your use of the products. Without limiting this general disclaimer the following specific warnings and disclaimers also apply:

Fitness for Purpose

You agree that you have been provided with a reasonable opportunity to appraise the products and have made your own independent assessment of the fitness or suitability of the products for your purpose. You acknowledge that you have not relied on any oral or written information, representation or advice given by or on behalf of Xtralis or its representatives.

Total Liability

To the fullest extent permitted by law that any limitation or exclusion cannot apply, the total liability of Xtralis in relation to the products is limited to:

- (i) in the case of services, the cost of having the services supplied again; or
- (ii) in the case of goods, the lowest cost of replacing the goods, acquiring equivalent goods or having the goods repaired.

Indemnification

You agree to fully indemnify and hold Xtralis harmless for any claim, cost, demand or damage (including legal costs on a full indemnity basis) incurred or which may be incurred arising from your use of the products.

Miscellaneous

If any provision outlined above is found to be invalid or unenforceable by a court of law, such invalidity or unenforceability will not affect the remainder which will continue in full force and effect. All rights not expressly granted are reserved.

Contact Us

www.xtralis.com

Contents

1	General	3
1.1	Scope.....	3
1.2	Codes, Standards or Regulations	3
1.3	Quality Assurance.....	3
1.3.1	Manufacturer	3
1.3.2	Equipment Supplier	3
1.3.3	Installer	3
1.3.4	Warranty	4
1.3.5	Training.....	4
2	Overview	5
2.1	Product Description.....	5
2.2	Ordering Information	5
2.3	Key Features and Benefits	5
2.4	Certifications and Compliance Standards.....	6
2.5	Product Specification	7
2.5.1	Dimensions and Weight.....	7
2.5.2	Operating and Environmental Conditions.....	8
2.5.3	Off-gas Sensor Parameters	8
2.5.4	Interface Module Parameters	9
3	Installation and Configuration	10
3.1	Preparation	10
3.2	Selection of the Installation Location	10
3.3	Installation Instructions.....	11
3.4	Sensor Mounting.....	12
3.5	Network Cable Requirements	13
3.6	Installing the Interface Module	13
3.7	Configuration and Settings.....	14
3.8	Commissioning	15
4	Bump Test Procedure	16
4.1	UL2075 Compliance	16
4.2	Non UL2075 Compliance	17
5	Maintenance and Service	19
5.1	Maintenance Tests	19
5.2	Spare Parts	19
6	Communication Function	20
6.1	Function Description	20
6.2	Interface Description	21
6.2.1	Relay Port	21
6.2.2	485Port and CAN Port.....	21
6.3	Communication Protocols	22
6.3.1	RS485-Modbus Commands 485 Interface Communication Protocol.....	22

1 General

1.1 Scope

This document provides specification details on the Li-ion Tamer Sensor MOS designed to assist users in the installation, operation, and maintenance of the system.



Important Notes!

- This Li-ion Tamer Sensor MOS detects the venting of electrolyte solvent vapours from lithium-ion batteries during the initial cell venting. It also detects hydrogen gas generated during cell thermal runaway. It does not prevent fires or thermal runaway. This device is not a stand-alone safety device and should be incorporated into a proper safety system. If device responds, there is a risk of battery fault which could lead to thermal runaway. To avoid injury, leave area immediately.
- The Li-ion Tamer Sensor MOS must be powered OFF when the battery system is being commissioned, tested, maintained, etc.
- The Li-ion Tamer Sensor MOS is intended for operating battery systems, so alarms may be activated if exposed to cross-sensitive gases from the environment surrounding the battery system.

1.2 Codes, Standards or Regulations

The Li-ion Tamer Sensor MOS shall be installed in the battery system in accordance with the following codes and regulations:

- Any national or international standards or fire codes that requires the detection of electrolyte vapours (off gassing phase).
- Any national or international standards or fire codes that require detection of flammable gases (H₂) at or below 10% of the LFL (ex. NFPA 855/ NFPA 69).
- Local codes and standards.

1.3 Quality Assurance

1.3.1 Manufacturer

The manufacturer has an ISO 9001:2015 registered quality system and is committed to achieving the following objectives:

- Development of innovative process and product solutions.
- On-time delivery of products and services to our customers.
- Providing safety and empowerment for our team members.
- Continuous improvement of operations and our quality system.

1.3.2 Equipment Supplier

- The equipment supplier shall attend the manufacturer's authorized training to be able to perform the design, installation, testing and maintenance of Li-ion Tamer Sensor MOS.
- The equipment supplier shall be able to present a training certificate issued by the manufacturer.

1.3.3 Installer

- The equipment installers shall be authorized and trained by the manufacturer and shall be able to design the system based on code requirements.
- The installer shall have the ability to provide design, and test documentation upon request.

1.3.4 Warranty

- The manufacturer shall provide a two-year warranty for the product and guarantee that the target lifetime of the product is more than ten years.
- The installation and configuration of the system shall be performed by trained suppliers or commissioning parties.

1.3.5 Training

The manufacturer or the manufacturer's agent shall provide the training for all personnel involved in the supply, installation, commissioning, operation or maintenance of the lithium-ion battery safety monitoring system. Please contact a Honeywell/Xtralis or Nexceris representative to schedule a training session.

2 Overview

2.1 Product Description

The Li-ion Tamer Sensor MOS is a device that detects hydrogen gas, which is generated during thermal runaway of lithium-ion batteries. The detection of hydrogen allows proper management of flammable gas accumulation to avoid explosive conditions.

It is also capable of detecting the initial venting of battery electrolyte solvent vapours (off-gassing phase) that occurs early in the failure mode of lithium-ion batteries. The early detection of such events allows proper mitigation steps to be taken to avoid a catastrophic thermal runaway failure. The Li-ion Tamer Sensor MOS is designed to be plug-and-play, easy to install and consists of two primary components, (1) off-gas sensor, (2) interface module.

1. Off-gas sensor comprises on-board detection algorithms making it acutely sensitive to hydrogen gas and lithium-ion battery electrolyte solvent vapours, is compatible with all lithium-ion battery form factors and chemistries and has a lifetime comparable to a typical lithium-ion battery system.
2. The off-gas sensor is connected to the interface module, which allows real-time monitoring of the sensor status and timely detection of battery electrolyte vapour emissions. The module provides 3 relay outputs and Modbus 485/ CANbus serial outputs that can be used to electrically isolate the battery system and activate the ventilation system.

2.2 Ordering Information

Ordering Code	Description	Remarks
LT-SEN-MOS	Li-ion Tamer Sensor MOS	Main Assembly (comprises LT-SEN-M and LT-SEN-IM-UL)
LT-SEN-M	Li-ion Tamer Gen 2+ Sensor	Spare Part
LT-SEN-IM-UL	Li-ion Tamer Interface Module UL	Spare Part

2.3 Key Features and Benefits

- Early warning of lithium-ion battery failures
- Enable thermal runaway prevention with proper mitigation actions
- Single cell failure detection without electrical or mechanical contact of cells
- Extended product lifetime
- Highly reliable output signals
- Calibration-free product (only requires bump test)
- Low power consumption
- Compatible with all lithium-ion battery form factors and chemistries
- Easy installation
- Independent and redundant perspective on battery health
- Auto diagnostic capabilities
- Configurable communication protocols including Relay outputs and Modbus/CANbus communication
- Cost Effective solution for modular Battery Energy Storage Systems (BESS)
- Reduction/removal of false positive signals
- Support 2 alarm relay outputs and 1 fault relay output

2.4 Certifications and Compliance Standards

Certification of Off-Gas Sensor	Certification of Interface Module
<ul style="list-style-type: none"> UL 2075 Recognized Component (Hydrogen gas) ETL listed to UL 61010 and CSA 22.2 NO. 61010 for product safety EMC according to EN 61326 for EU Directive (2014/30/EU) RoHS 3 Compliance (EU 2015/863) UKCA CE FCC 	<ul style="list-style-type: none"> Certification of fire alarm system module UL864 10th Safety UL61010-1 RoHS EN50581-2002 EMI EN55011-2010 EMC EN61326-1-2021

Interface Module Environmental and Hazardous Substances Table:

Part Name	Hazardous Substance					
	Lead (Pb)	Mercury (Hg)	Cadmium (Cd)	Hexavalent Chromium (Cr(VI))	Polybrominated Biphenyls (PBB)	Polybrominated Diphenyl (PBDE)
Enclosure assembly	O	O	O	O	O	O
Assembly accessories	O	O	O	O	O	O
Circuit board assembly	O	O	O	O	O	O

This table is prepared in accordance with the provisions of SJ/T 11364.

O: It indicates that the content of the hazardous substance in all homogeneous materials of the part is below the limit requirements specified in GB/T 26572.

X: It indicates that the concentration of the hazardous substance in at least one homogeneous material of the part exceeds the limit requirements specified in GB/T 26572. Other parts not included in the table do not contain any restricted substances that exceed the limit requirements.

Off-Gas Sensor Environmental and Hazardous Substances Table:

Part Name	Hazardous Substance					
	Lead (Pb)	Mercury (Hg)	Cadmium (Cd)	Hexavalent Chromium (Cr(VI))	Polybrominated Biphenyls (PBB)	Polybrominated Diphenyl (PBDE)
Monitoring Sensor, GEN 2+	X	O	O	O	O	O

This table is prepared in accordance with the provisions of SJ/T 11364.

O: It indicates that the content of the hazardous substance in all homogeneous materials of the part is below the limit requirements specified in GB/T 26572.

X: It indicates that the concentration of the hazardous substance in at least one homogeneous material of the part exceeds the limit requirements specified in GB/T 26572. Other parts not included in the table do not contain any restricted substances that exceed the limit requirements.

- EPUP 10 years
- All other components, not listed in the table, do not contain restricted substances above the threshold level.

2.5 Product Specification

2.5.1 Dimensions and Weight

Off-gas Sensor

External dimensions of off-gas sensor: 28.58 mm (D) x 25.4 mm (L)

Weight approx.: 36 g

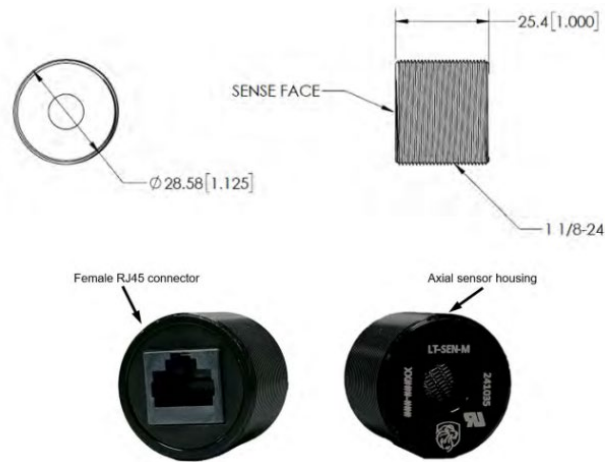

Interface Module

External dimensions of interface module: 140 mm (L) x 85 mm (W) x 34 mm (H)

Weight approx.: 351 g

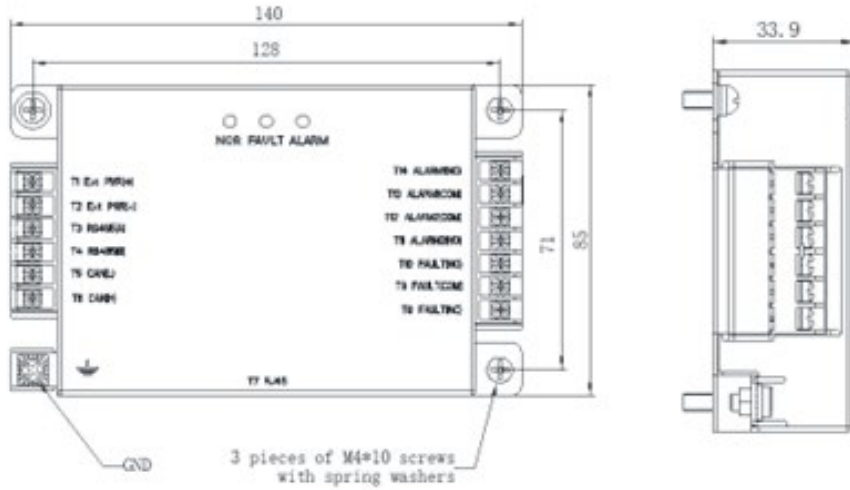

2.5.2 Operating and Environmental Conditions

Off-Gas Sensor:

Operating Temperature Range	-40 °C to 50 °C
Operating Humidity Range	5% to 90% RH (non-condensing)
Storage Temperature	5 °C to 30 °C
Storage Humidity	10% to 80% RH
Pressure	95 to 110 kPa
Maximum Temperature Change	8.6°C/ min

Interface Module:

Operating Temperature Range	-40 °C to 70 °C
Operating Humidity Range	5 % to 95 %RH (non-condensing)

2.5.3 Off-gas Sensor Parameters

General Specifications	
Working voltage	5-12 VDC ± 10% (5 VDC nominal)
Target gases	Hydrogen gas Lithium-ion battery off-gassing compounds (battery electrolyte solvent vapours)
Min. Detection Threshold <i>(Refer to Section 2.5.3.1 for more details)</i>	10 ppm/second (hydrogen gas) < 1 ppm/second (electrolyte solvents)
Min. Response Time	5 seconds
Connector	RJ45
Product Life Specifications	
Target lifetime	> 10 years

2.5.3.1 Target Gases

The following is a list of common gases/compounds emitted by lithium-ion batteries that Li-ion Tamer is sensitive to:

- Hydrogen (H₂) –sensor provides detection of hydrogen at or below 10% of the LFL
 - Minimum Gas Rate: 10 ppm/sec
 - Maximum Gas Rate* : 400 ppm/sec
- Battery electrolyte solvent vapours:
 - Diethyl carbonate (DEC)
 - Dimethyl carbonate (DMC)
 - Ethyl methyl carbonate (EMC)

* The sensor can respond to gas generation rates greater than this level, but this is the maximum recommended rate of change in accordance with sensor response time and adherence to NFPA 855/ NFPA 69 code requirements of activation prior to 10% of LFL concentration (4000 ppm H₂).

2.5.4 Interface Module Parameters

General Specifications	
Working voltage	15 – 32 VDC Typical 24 VDC
Number of 485/CAN networks for the interface module	12
System outputs	3 Relay outputs / Modbus / CANbus
Sensor interface specifications	RJ45
Power Consumption Specifications	
Interface module (without sensors)	Max 240 mW (@ 24 VDC)
Interface module (with sensors)	65mA, Max 1.56W (@ 24VDC)
Rated current of interface module fuse	200 mA
Relay Specifications	
Relay load	Max 30 VDC 2A Max 125 VAC 0.5 A
Alarm relay	2 sets, NO/ NC (S/W), latched (Power Reset, Modbus / CANbus Reset)
Modbus RS485 Communication Specifications	
Baud rate	9600
Parity	N
Stop bit	1
Hardware	RS485 2-wire
Distance of communication	20 m
CANbus Communication Specifications	
Data rate	125 K bit/s (Default)
Frame structure	Standard frame
Distance of communication	20 m

3 Installation and Configuration

3.1 Preparation

- Prepare the sensors, interface modules, and accessories necessary for installation.
- Plan the installation positions and cabling of sensors and interface modules.
- Ensure that the sensor and interface module are fully functional.
- For networking via RS485 or CANbus, individual addresses must be assigned to each Interface Module.

3.2 Selection of the Installation Location

Appropriate Off-gas Sensor placement:

- Near or on the battery rack to detect off-gassing from rack.
- Near vent outlets on the exhaust side of the cooling air (i.e. hot aisle).

Several examples of sensor rack layouts are shown below:



Example #1

Type: air enters from the back of the rack and exits out the front

Sensor placement: top front of the rack

Sensor orientation: sensing face pointing down ($\pm 45^\circ$)

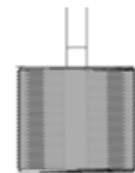

Sensing face
Pointing down



Example #2

Type: air enters from the top of the rack and exits out the bottom

Sensor placement: bottom center of the rack

Sensor orientation: sensing face pointing at 90° to vertical ($\pm 45^\circ$)

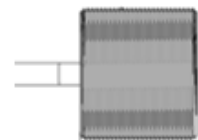

Sensing face
Pointing horizontal



Example #3

Type: air enters from the bottom of the rack and exits out the top

Sensor placement: top center of the rack

Sensor orientation: sensing face pointing at 90° to vertical ($\pm 45^\circ$)



Sensing face
Pointing horizontal



Avoid Off-gas Sensor placement in the following areas:

- Entrance/ exit locations to the battery space (doors, access points, etc.).
- Possible gas entry points to the battery space (forced air or passive vent, unsealed gaps, etc.).
- HVAC entry points into the battery space.

3.3 Installation Instructions

All installations shall be performed by a trained Xtralis representative. The following steps outline the installation process:

1. Mount Off-gas Sensor
2. Mount Interface Module near the Off-gas Sensor (max distance 6m (19.7ft)).
3. Route Network cable from Off-gas Sensor to Interface Module.
 - Ensure the cable is not in tension (provide sufficient slack to avoid potential damage).
 - Utilize cable trays whenever possible.
 - Avoid mounting the cabling components in places that block accessibility to other equipment (such as a power strip or fans) in/out of the racks.
 - Avoid exposing the cable to areas of condensation and direct sunlight.
 - Provide strain-relief when mounting cables to prevent connection issues.
 - Observe all recommended practices from the cable manufacturer including bend radius, etc.
4. Wire Interface Module to an appropriate control device.
 - Direct relay connection, via I/O modules (i.e. NFS-320E fire alarm panel). Refer to the below UL864 certified wire diagram.

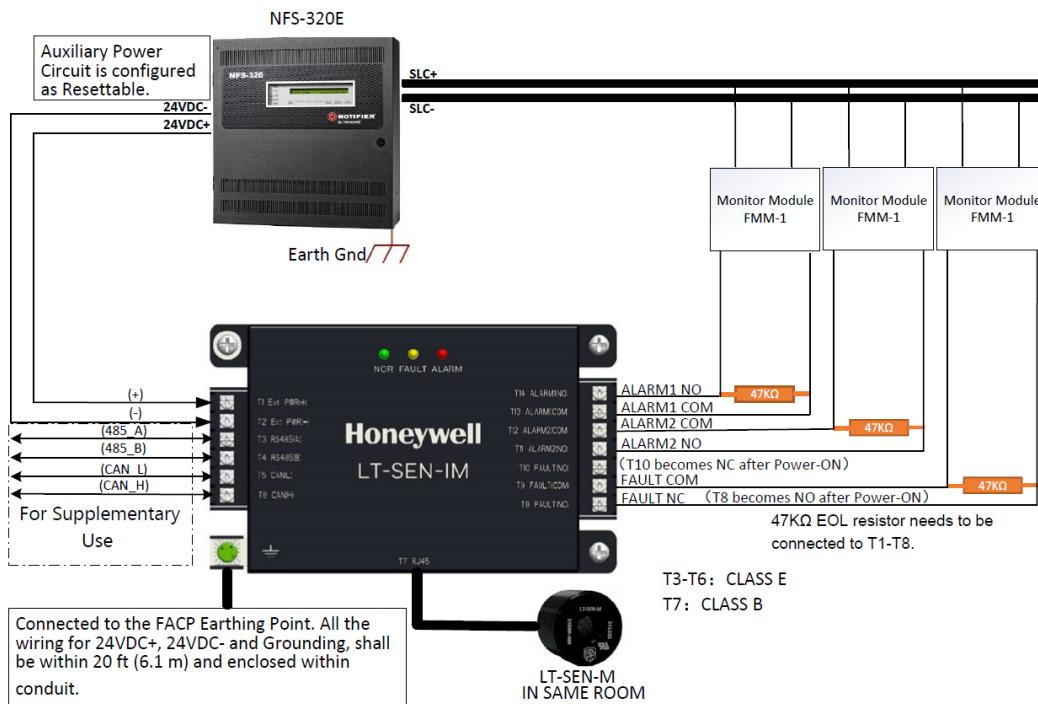

Terminal	Required
T1-T6	18-20 AWG
T8-T14	18-20 AWG, Refer to FMM-1 manual for maximum line impedance and end of line resistor
T7 RJ45	Max 6mm, Min 24 AWG

- RS485 or CANbus loop in third party software or battery management system
 - Daisy chain connection, max 12 Interface Module units.
 - The last Interface Module unit must connect with EOL resistor.
 - Configure the Interface Module (see section 3.5 Configuration and Settings)

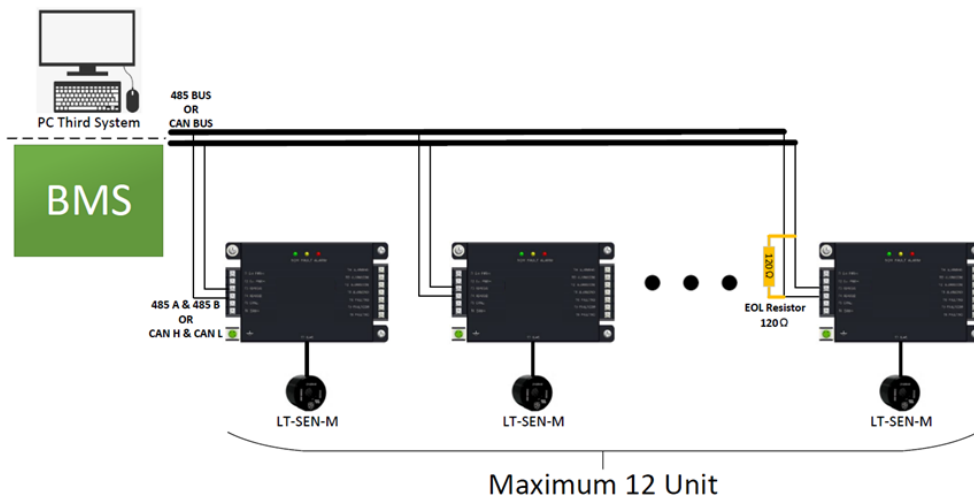

Warning!

Ensure that the Network cable is not in tension when connected to the Interface Module. Make sure to provide enough slack to avoid potential damage.

5. Power ON the Interface Module.
6. Follow the commissioning process.

3.4 Sensor Mounting

The Off-gas sensor may be mounted using one of two methods. Option 1 is to create a through-hole on the panel the sensor is to be mounted on. Option 2, depicted below, is to use the supplied mounting bracket. The following procedure should be used:

1. Fasten mounting bracket in position determined in the system layout.
2. Secure sensor to bracket using the supplied 1 1/8-24 mounting nuts.
3. Hand-tighten nuts to secure the sensor to the bracket.

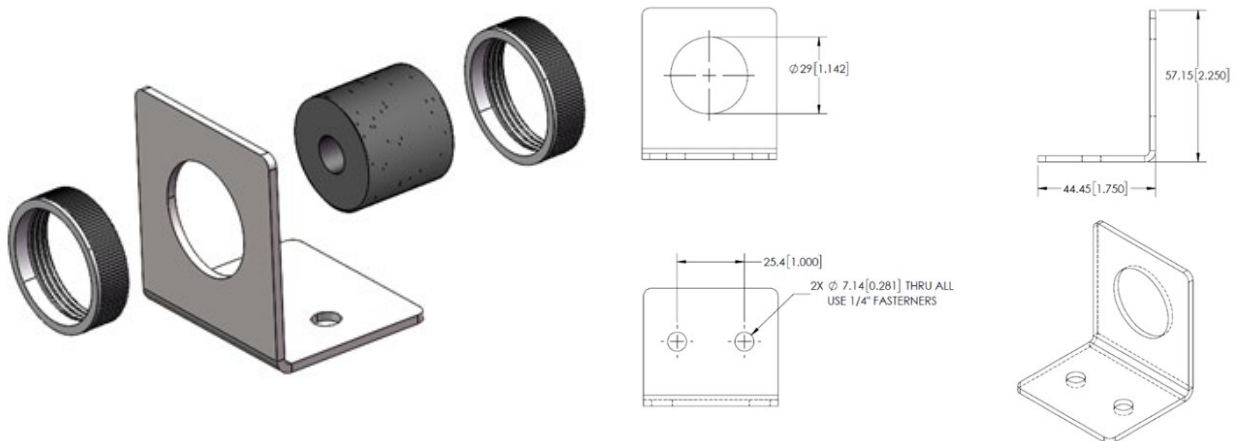

3.5 Network Cable Requirements

The requirements for cables used in this application are as follows:

- Must be Cat 5e or Cat 6a, straight through, **shielded** (at least S/UTP), 24 – 26 AWG cable.
- Connector plugged into the sensor should be **unshielded** and connector plugged into the interface module should be shielded for ideal ESD protection.

3.6 Installing the Interface Module

Installation diagram of LT-SEN-IM Interface Module

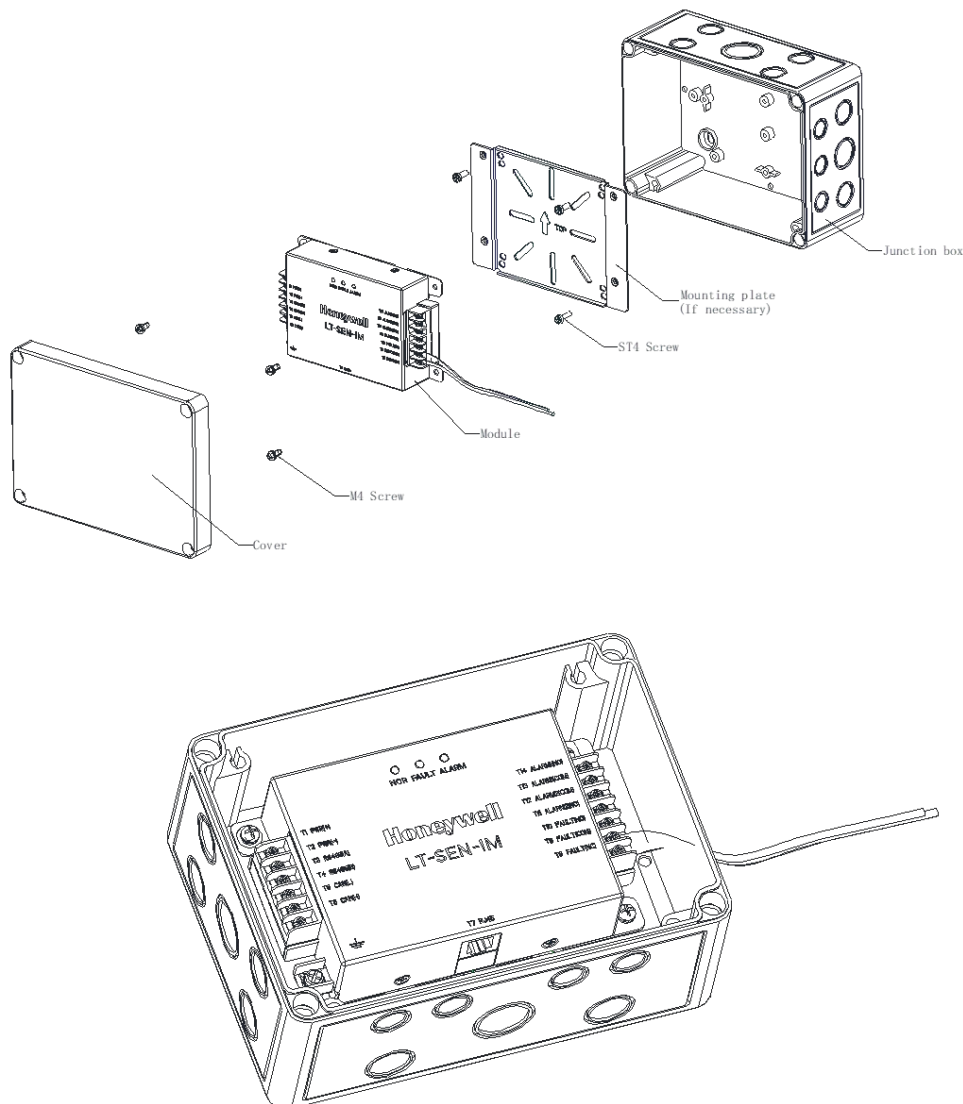

Mounting and Wiring

Follow the below steps to install the Interface Module:

1. The interface module must be installed in a junction box (supplied by the installer). The Spelsberg TK PC 1813-9-m junction box shown in the above installation diagram can be used (Example supplier: <https://www.spelsberg.com/> or Junction box direct <https://www.spelsberg.com/industrial-housing/with/-without-metric-knock-outs/12741601/>).
2. The recommended installation method is as follows:
 - a. **Method 1:** The installation plate is first fixed to the junction box using 4 ST4 screws, and the interface module is fixed to the installation plate using 3 M4 screws (if necessary).
 - b. **Method 2:** The interface module is fixed to the junction box using 3 M4 screws.

3. The module wiring must be connected according to the design drawing instructions.



Note!

All connection wires must comply with local laws, regulations, and related provisions.

3.7 Configuration and Settings

The off-gas sensor can be used directly without configuration. The following steps outline the configuration settings of the Interface Module.

Interface Module Read Status:

<ul style="list-style-type: none"> Step 1: Download “<i>Li-ion Tamer Interface Module Config Software</i>” from the Li-ion Tamer Sensor MOS Product Page on Xtralis website (https://xtralis.com/product/267/li-ion-tamer-sensor-multi-output-solution). Step 2: Connect PC (≥ windows10) to Interface Module (converter/driver USB to RS485 required). Step 3: Open “Li-ion Tamer Interface Module. Config Software” and select “Language”. Step 4: Click “Serial Port” (select assigned port). Step 5: Click “Open” Step 6: <ul style="list-style-type: none"> Click “Read Address” – current Modbus address of Interface Module. Click “Ask Status” – F/W version, Sensor status (Normal, Alarm, Fault), Alarm Relay configuration. 	
---	--

Interface Module change Alarm Relay Configuration (Non UL864 compliant):

<ul style="list-style-type: none"> Follow steps 1-6 to read status. Step 7: Click dropdown menu next to “Modify Alarm Relay” and select NC/ NO. Step 8: Click “Modify Alarm Relay”. Step 9: Confirm change when prompted. <p>Important Note: UL864 only certified Alarm relay output as NO default.</p>	
--	--

Interface Module Change Modbus Address (default: #2):

- Follow steps 1-6 to read status.
- Step 7: Click dropdown menu next to “Modify Address” and select new address.
- Step 8: Click “Modify Address”
- Step 9: Confirm change when prompted.

**Notes!**

- Assign individual Address numbers when >1 Interface Modules are networked in a loop.
- One Interface Module can be Read/ Configured at a time.

3.8 Commissioning

When the system installation is completed, follow the steps below for functional integrity check:

1. Verify that the system cables are properly connected.
2. Ensure that the earth terminal of interface module is connected to the earth ground terminal of the BESS host control system.
3. Ensure host control system is in stand-by mode.
4. Trigger the Off-gas Sensor alarm with a target gas (Electrolytes, Hydrogen).
5. Check the Interface Module for Alarm LED (Red).
6. Check the Interface Module Alarm Relay is triggered (multi-meter, host control system).
7. Disconnect the Off-gas Sensor.
8. Check the Interface Module for Fault LED (Yellow).
9. Check the Interface Module Fault Relay is triggered (multi-meter, host control system).

4 Bump Test Procedure

4.1 UL2075 Compliance

This section describes how to perform a bump test for commissioning and maintenance procedures. Bump testing is the process of exposing the gas sensor to a known concentration of reference gas that is of sufficient concentration to alarm the sensor. Follow the procedure below to correctly test sensors.

Required Materials for Testing:

- 1000ppm H₂ Calibration Gas Balance Air
- Gas Regulator (must be minimum 0.5 lpm)
- Gas Tubing (vinyl is recommend) – maximum OD of 5/16 inch (~8mm)
- Safety Glasses (recommended)



Notes!

- Always use a flow regulator, tubing and fittings appropriate for the type of gas being applied.
- Always use a gas cylinder that is within its expiration date.
- Example Gas Suppliers: Calgaz (<https://calgaz.com/>), Cal Gas Direct (<https://www.calgasdirect.com/>)

How to Use:

1. Insert the tube from the calibration gas cylinder into the sensing face port on the sensor.

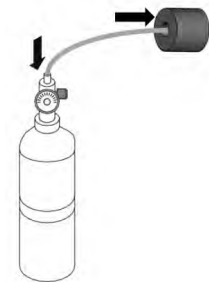

2. Refer to the regulator manufacturer for instructions on how to start and stop the gas flow from the cylinder.



3. Expose sensor to gas at a constant flow rate for 30 seconds. Flow rate and tubing length must be considered to ensure that the sensor is exposed to H₂ for the full duration.
4. Observe sensor response and confirm appropriate alarm activation.
5. If the sensor fails the bump test, it must be replaced.



Note!

You must perform a bump test at least once a year.

4.2 Non UL2075 Compliance

For locally sourced Diethyl Carbonate liquid consult Li-ion Tamer Bump Test Kit Application Note (Doc. No. 37440) for kit setup.

Alternatively, the Li-ion Tamer DEC Test Bottle (LT-ACC-TST) may be provided by Xtralis upon request. The small bottle, shown below, is filled with a small amount of diethyl carbonate to be used for bump testing of sensors. This liquid must be safely transferred into the larger puff-test bottle prior to testing the sensors. Follow the procedure below to correctly test sensors.



Notes!

- Use proper personal protective equipment when transferring liquid between bottles. It is important that the puff-test bottle never be turned up-side down during use and is not intended to be refilled.
- If the product is being shipped, please transfer the liquid back into the small bottle. To maximize the lifetime of the test kit, store the liquid in the small bottle.

Required Materials for Testing:

- Li-ion Tamer DEC Test Bottle
- Latex gloves (recommended)
- Safety glasses (recommended)

How to Use:

1. Position the bottle relative to the OGM under test, like the example shown below.



2. Open the tab on the cap.
3. Firmly squeeze the bottle to release a puff of headspace gas towards the sensor face.

**Warning!**

Avoid ejecting liquid from the bottle, especially onto the sensor. If the sensors were recently powered on, wait at least 30 minutes prior to testing.

4. Observe sensor response and confirm appropriate alarm activation.

5 Maintenance and Service

5.1 Maintenance Tests

The Li-ion Tamer Sensor MOS requires minimal operation and maintenance. The general steps are detailed below and shall be performed annually:

1. Immediately attend to any faults generated by the interface module.
2. Perform a visual inspection.
 - Check the interface module, cabling, and sensor placement for physical damage, or other visual changes to the original system construction.
 - Inspect sensor for excessive dust build up at the inlet. Sensor inlet is protected by a 40µm breather vent. This prevents diffusion restriction from dust build up from impacting the operation of the off-gas sensor; however, excessive dust should be removed from the inlet of the sensor as a best practice.

**Note!**

Do not use compressed air dusters as they can alarm and potentially damage sensors.

- Ensure that mounting nuts are tightened to secure sensor to mounting bracket.
3. Perform a bump test on the sensor to verify the gas response.
 - Procedure in Section 4.1 must be used to maintain UL 2075 compliance.
 - Procedure in Section 4.2 may be used if UL 2075 compliance is not necessary.

5.2 Spare Parts

Spare parts may be provided by Xtralis upon request.

6 Communication Function

6.1 Function Description

The interface module can report the sensor status to the main system controller via relay/485/CAN.

Monitor module relay and LED status description:

Sensor State	Relay Output	LED Status
Normal	ALARM1 NO & ALARM1 COM: Open ALARM2 NO & ALARM2 COM: Open FAULT NO & FAULT COM: Closed FAULT NC & FAULT COM: Open	LED NOR, Green, Steady
Alarm	ALARM1 NO & ALARM1 COM: Closed ALARM2 NO & ALARM2 COM: Closed FAULT NO & FAULT COM: Closed FAULT NC & FAULT COM: Open	LED Alarm Red, Steady
Fault	ALARM1 NO & ALARM1 COM: Open ALARM2 NO & ALARM2 COM: Open FAULT NO & FAULT COM: Open FAULT NC & FAULT COM: Closed	LED FAULT, Yellow, Steady
Initialization	ALARM1 NO & ALARM1 COM: Open ALARM2 NO & ALARM2 COM: Open FAULT NO & FAULT COM: Closed FAULT NC & FAULT COM: Open	LED NOR, Green, Blink
Sensor Unconnected	ALARM1 NO & ALARM1 COM: Open ALARM2 NO & ALARM2 COM: Open FAULT NO & FAULT COM: Open FAULT NC & FAULT COM: Closed	LED FAULT, Yellow, Steady

6.2 Interface Description

The below table explains the interface of the interface module:

Function	Description	Function	Description
T1 Ext PWR(+)	Power Supply +	T14 Alarm1 NO*	Alarm relay port 1
T2 Ext PWR(-)	Power Supply -	T13 Alarm1 COM	
T3 RS485A	RS485 A	T12 Alarm2 COM	Alarm relay port 2
T4 RS485B	RS485 B	T11 Alarm2 NO	
T5 CANL	CAN Bus L	T10 Fault NO	Fault relay port
T6 CANH	CAN Bus H	T9 Fault COM	
T7 RJ45	Connect the monitor sensor	T8 Fault NC	

* Alarm Relay 1 and Alarm Relay 2 are triggered and disarmed at the same time. They are at the same alarm level.

6.2.1 Relay Port

Relay	Set Condition	Reset Condition
Alarm 1 and 2	Alarm condition reached	Latched: Alarm reset sequence from user
Fault	Fault condition reached	Unlatched: Fault condition ended

6.2.2 485Port and CAN Port

Function	Description	Note
Read State	Host Queries the status of the slave	Support RS485 and CANbus
Read and Write Address	The host reads and overwrites the slave network address	Support RS485 and CANbus Point-to-point command
Reset	The host can reset the corresponding address slave and reset the alarm relay in the locked state	Support RS485 and CANbus
Self-Check	The host can send the self-check command to put the slave machine in the self-check state for 5s, enable all LEDs and relays for the slave, and return the current Li-ion Tamer sampling voltage.	Support RS485 and CANbus
Read Firmware Version	Host Queries the firmware version of the slave	Support RS485 and CANbus

6.3 Communication Protocols

6.3.1 RS485-Modbus Commands 485 Interface Communication Protocol

The interface module supports Modbus RTU communication on the RS485 bus. The status, address and software version information of the interface module can be obtained via Modbus RTU, and the address of the interface module can be set to enable the interface module to enter a self-check status or reset the interface module.

Communication parameters for 485:

Baud: 9600 bit/s; Parity: None; Data Bites: 8bits; Stop Bits: 1bit.

Details of Modbus RTU are shown in the below table:

Description	Function Code	Register Number (hex)	Register Number (decimal)	Register Data
State	0x03	0x4001	16385	0x0001: Normal state 0x0002: Alarm status 0x0003: Fault status 0x0004: Initialization status
Address	0x03/0x06	0x4002	16386	2~63
Self-Check	0x06	0x4004	16388	0x0001
Software Version	0x03	0x4005	16389	0xmn (Vm.n)
Reset	0x06	0x4006	16390	0x0001
Alarm Relay Configuration	0x03/0x06	0x4007	16391	0x0000: NO (default) 0x0001: NC (Non UL864 compliant)



Note!

Address the X register number by sending the X-1 register address.

The interface module supports CANbus communication and can be connected to the L and H lines of the CANbus separately.

It is recommended to use twisted pair cables for the CAN communication device connection.

Detailed information on CAN communications can be found below:

The CANbus communication baud rate is 125 Kbps with the CAN standard data frame for communication.

Define 11-bit CAN ID as follows:

1 bit	4 bits	6 bits
Direction of data transmission	Function code	Address
0: Master to slave 1: Slave to master	0001 indicates that the module status has been obtained 0010 indicates that the module address has been obtained 0011 indicates that the module address has been set 0100 indicates that it enables the module self-check 0101 indicates that it enables the module reset	Default: 00 0010

**Note!**

Slave Module address is 2 as default.

The status value of the module is listed in the table below:

Value	State
0x01	Normal
0x02	Alarm
0x03	Fault
0x04	Initialization

0001 Function Code Definition: Master read status from slave

Identity			DLC	Data
1 bit Direction	4 bit Function Code	6 bit Address	4 bit	1 Byte
0	0001	00 0010		
0x042			0x1	0x00

Interface Module response function code 0001

Identity			DLC	Data
1 bit Direction	4 bit Function Code	6 bit Address	4 bit	1 Byte
1	0001	00 0010		
0x442			0x1	0x01: Normal 0x02: Alarm 0x03: Fault 0x04: Initialization

0010 Function Code Definition: Master Read the address from slave

Identity			DLC	Data
1 bit Direction	4 bit Function Code	6 bit Address	4 bit	1 Byte
0	0010	00 0000		
0x080			0x1	0x00

Interface Module Response function code 0010

Identity			DLC	Data
1 bit Direction	4 bit Function Code	6 bit Address	4 bit	1 Byte
1	0010	00 0010		
0x482			0x1	0x02

0011 Function Code Definition: Set the address* command

Identity			DLC	Data
1 bit Direction	4 bit Function Code	6 bit Address	4 bit	1 Byte
0	0011	00 0010	0x1	0x03
0xC2				

* The address range is from 1~63

Interface Module response the function code 0011

Identity			DLC	Data
1 bit Direction	4 bit Function Code	6 bit Address	4 bit	1 Byte
1	0011	00 0011	0x1	0x03
0x4C3				

0100 Function Code Definition: Self-Test (All LEDs is ON, and Relay is activated, keep for 5 seconds and then recover the status)

Identity			DLC	Data
1 bit Direction	4 bit Function Code	6 bit Address	4 bit	1 Byte
0	0100	00 0010	0x1	0x00
0x102				

Interface Module Response Function code 0001

Identity			DLC	Data
1 bit Direction	4 bit Function Code	6 bit Address	4 bit	2 Bytes
1	0100	00 0010	0x2	ADC Sample Value (voltage of sensor output)
0x502				

0101 Function Code Definition: Reset Command

Identity			DLC	Data
1 bit Direction	4 bit Function Code	6 bit Address	4 bit	1 Byte
0	0101	00 0010	0x1	0x01
0x142				

Interface Module Response Function Code 0101

Identity			DLC	Data
1 bit Direction	4 bit Function Code	6 bit Address	4 bit	1 Byte
1	0101	00 0010	0x1	0x01
0x542				

0110 Function Code Definition: Read Firmware Version

Identity			DLC	Data
1 bit Direction	4 bit Function Code	6 bit Address	4 bit	1 Byte
0	0110	00 0010	0x1	0x00
0x182				

Interface Module Response Function Code 0110

Identity			DLC	Data
1 bit Direction	4 bit Function Code	6 bit Address	4 bit	2 Byte
1	0110	00 0010	0x2	0x01 0x00
0x582				

0111 Function Code Definition: Set Baud rate (Broadcasts) Power reset is available

Identity			DLC	Data
1 bit Direction	4 bit Function Code	6 bit Address	4 bit	1 Byte
0	0111	00 0000	0x1	0x00
0x1C0				

Interface Module Response Function Code 0111

Identity			DLC	Data
1 bit Direction	4 bit Function Code	6 bit Address	4 bit	1 Byte
1	0111	00 0010	0x1	0x00:125K Default 0x01:50K 0x02:100K 0x03:125k 0x04:250k 0x05:500k
0x5C2				