

---

# PIPE NETWORK BACK FLUSH (VESDA) APPLICATION NOTE

---

June 2020  
Doc. No. 20016\_04

---

## **Preface**

This Application Note provides guidelines on the Xtralis VESDA pipe network maintenance via means of back flushing. These guidelines when followed will ensure reliable system performance.

## **Related Products**

This Application Note can be applied to all VESDA detectors (excluding VEA).

# Contents

<b>1</b>	<b>Introduction.....</b>	<b>1</b>
<b>2</b>	<b>Back Flush .....</b>	<b>2</b>
<b>3</b>	<b>Further Support .....</b>	<b>4</b>

# 1 Introduction

Proper maintenance of the Xtralis VESDA pipe network ensures continued reliable system performance.

Pipe network maintenance is intended to dislodge dust and contaminants from the pipe network through back flushing using vacuum pressure or compressed air.

## 2 Back Flush

The back flush setup is implemented close to the Xtralis VESDA detector (downstream from sample holes). Two back flush configurations can be used.

### 1. 2 x 2-way Valves

As shown in Figure 1 during normal sampling (Normal Operation Mode); Valve #1 is open and Valve #2 is closed. To back flush the pipe network (Back Flush Mode); Valve #1 is closed and Valve #2 is open.

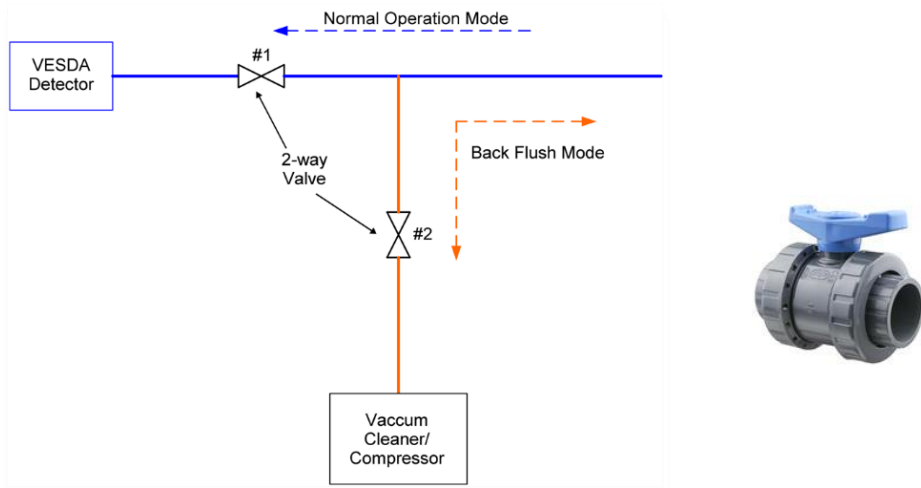

(a) Set-up

(b) 2-way Valve

Figure 1: Back Flush: 2 x 2-way Valves Configuration

### 2. 1 x 3-way Valve

As shown in Figure 2 the 3-way valve can be easily set to divert the flow intended for the Normal Operation and Back Flush modes.

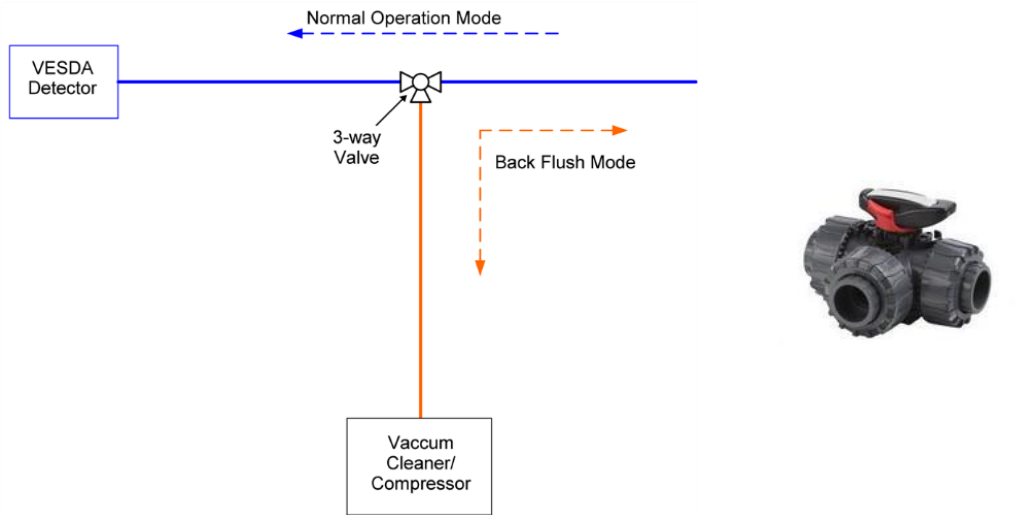

(a) Set-up

(b) 3-way Valve

Figure 2: Back Flush: 1 x 3-way Valve Configuration



**Note!**

The pipe ends must be solvent glued onto the valve's end connectors.

## Normal Operation Mode

When in Normal Operation Mode, the 2-way or 3-way valves should provide an open (unrestricted) flow air path such the transport time of the Xtralis VESDA system is not affected. To ensure minimal flow restriction the internal effective diameter (not the inlet and exhaust ports) of the valve(s) must be similar to the internal diameter of the sampling pipe (a deviation less than 10% is accepted). Where this inspection is not possible then information must be obtained from the manufacturer. Where such information is not available then the valve should not be used.

## Back Flush Mode

An example of a setup for back flushing using compressed air is shown in Figure 3. The setup comprises stainless steel bushing, valve and fittings for connection to the compressed air hose which can be readily sourced from most suppliers.

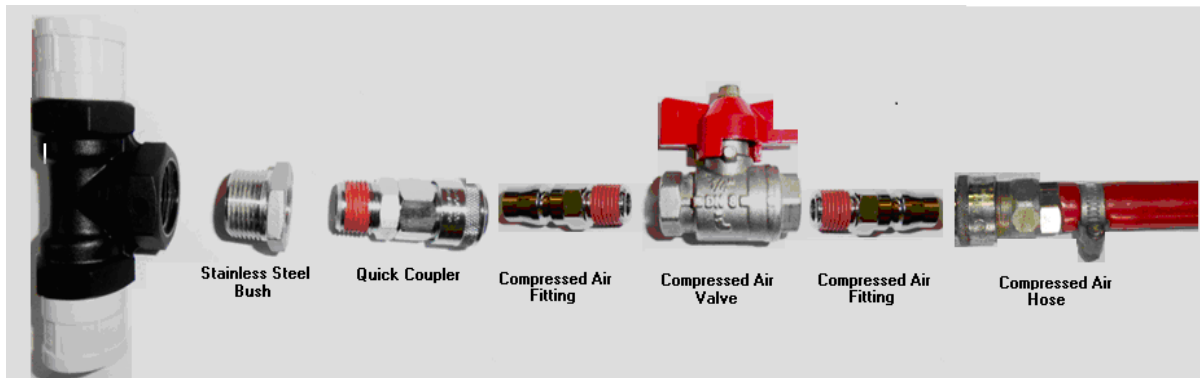

Figure 3: Compressed Air Line Component Setup

## Back Flush Procedure

Back flush frequency is expected to vary in accordance with the ambient background level where sampling occurs. The following steps will assist in identifying the appropriate back flush frequency for any environment.

1. Following one month of normal operation, under Normal Operation Mode, record the Xtralis VESDA detector raw flow or absolute flow rate (l/min), conduct a smoke test and record the transport time.
2. Set pipe network to Back Flush Mode.
3. Apply vacuum suction pressure using an industrial vacuum cleaner or compressed air using an air compressor for a period of 4min. Ensure both methods can deliver 300 to 500kPa pressure.
4. Set pipe network to Normal Operation Mode.
5. Record the Xtralis VESDA detector raw flow or absolute flow rate (l/min), normalise the airflow, conduct a smoke test and record the transport time.



### Note!

A deviation in excess of 10% in flow rate between the results of Steps 1 and 5 will indicate that the appropriate interval for the back flush activity is one month. However, if the deviation is less than 10% then the back flush interval can be extended by one month progressively until such time that the deviation exceeds 10%. Once the deviation has exceeded 10% the back flush interval is recommended to be done at the previous back flush interval. For example, if the variance is greater than 10% after three months from date of installation then the back flush interval will be every two months.

---

### 3 Further Support

Contact an Xtralis office or distributor for further information.