

Xtralis OSID Reflective Imaging Smoke Beam Detector

OSID-R



The OSI-R is a reflector-type linear optical beam smoke detector designed to operate as a component of fire alarm systems. The beam operates primarily on the principle of light obscuration utilising an Infra-Red beam. Optical beam smoke detectors are particularly appropriate for protecting buildings with large open spaces such as warehouses, atriums etc.

The OSI-R detector is a combined transmitter/receiver unit that can be directly connected to a conventional detector circuit.

InfraRed Transmitter and Receiver Imager

The Infra-Red transmitter and receiver Imager generates a beam of light towards a high efficiency reflector. The reflector returns the beam to the receiver where an analysis of the received signal is made.

The change in the strength of the received signal is used to determine the alarm condition.

The receiver imager has a wide FOV of 12° and tracks automatically the reflector in case of building movement or movement of its support structure. It is virtually impossible for the receiver to lose the reflector out of its side of view without any structural damage being caused to the building. As a result of this operation the OSI-R eliminates the number one cause of false alarms and/or faults with traditional beam detectors.

Optical Filtering

Optical filtering, high-speed image acquisition and intelligent software algorithms provide the OSID-R system with higher levels of stability and with greater resistance to high level lighting variability. As such the detector has a better resistance to sunlight and intruding objects in its FOV. The detector will not alarm when saturated by sunlight, reflected sunlight or any other very bright light sources. In worst case the detector will go in to trouble and hence solving another cause of false alarms with traditional basic photocell receiver beam detectors.

Thanks to the smoke imaging techniques the detector will not alarm for partial and sudden blockage.

Alignment

The alignment of the detector is extremely intuitive, fast and accurate. Both the IR transmitter and the CMOS imager are contained in the eyeball that can turn freely in all directions. The eyeball moves +/- 20° in the vertical direction and 50° in the horizontal direction.

Four arrows that indicate the direction to move the eyeball, will guide the user to find the imager's perfect alignment with the reflector.

To get started swiftly at long distances, a laser tool can be inserted in the eyeball to allow finding the reflector quickly and then fine-tuning the eyeball to the optimum alignment.

Once the optimum alignment is finalised, signalled by all green arrows and LED, the eyeball is locked by tightening the lever on its side. A paintable cover is then placed over the front to hide the alignment arrows, locking mechanism and secures the locking lever in locked position.

Unique in the market, the sensitivity of the detector is selected and set automatically at the optimum sensitivity based on the size of the reflector measured in the FOV.

The detector incorporates automatic drift compensation, whereby the detector will adjust its detection thresholds in line with any long term signal reduction of the beam caused by contamination of the optical surfaces.

An internal heating option is also provided on the Imager to prevent condensation on the optical surface.

Features

- Combined transmitter and receiver unit, range 16-328 ft (5-100 m)
- Conventional model
- Receiver consists of a CMOS imaging CCD
- Wide 12° field of view
- Intuitive beam alignment indicated by directional arrows
- Single IR wavelength
- Highly resistant to building movement; tolerates +/- 1° movement
- Resistant to strong light sources; does not alarm when saturated by sun
- Resistant to large solid intruding objects
- Automatic sensitivity threshold level setting
- 50° horizontal and 20° vertical beam alignment
- Built-in heater
- Electronic simulated smoke test from ground level
- Standby, fault and alarm LED indicators visible from the front and bottom
- Automatic drift compensation
- Paintable cover
- Removable plug-in terminal blocks
- Optional heater kit available for the reflector

Listings/Approvals

- CSFM
- UL
- ULC
- FM

Xtralis OSID Reflective Imaging Smoke Beam Detector

OSID-R

Status LEDs

Status information (Fire Alarm, Trouble and Power) is communicated through the Imager via Status LEDs on the front of the detector. The OSI-R detector comes with dedicated Trouble and Alarm relays and outputs for remote LED signalling. Specific Trouble (Fault) conditions are identified through coded flashes of the Trouble LED.

Where greater angular adjustment is required, the multi-mount accessory enables the detector to move through 28° vertically and 360° horizontally when ceiling mounted or up to 23° vertically and 90° horizontally when wall mounted.

To assure the correct operation of the system, a test can be initiated at convenience from ground level using the RTS151KEY unit. By activating the key, the unit will reduce its IR transmitted power till under the automatically set alarm level resulting in an alarm condition at the detector. The alarm condition will remain for as long as the key is activated.

To comply with local regulation and installation codes it may be required to use a test filter inside the beam path.

All Xtralis beam detectors are covered by our extended 3 year warranty.

Dimensions

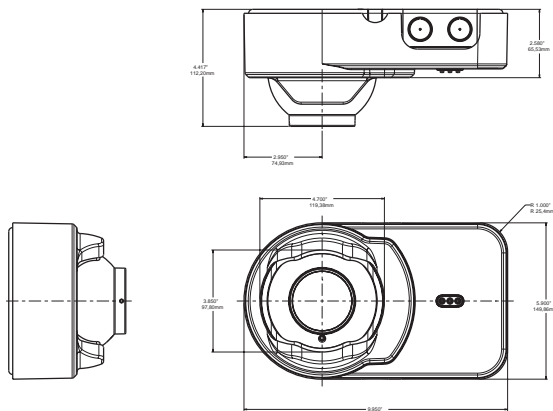

Installation Recommendations

Installation should be undertaken in accordance with recognised national or international standards and codes of practice.

Xtralis also recommends that simulated fire tests are conducted to ensure that the desired response time for a given smoke test is achieved.

Ordering Codes

OSI-R	Conventional imaging smoke beam smoke detector including reflector - UL approved
OSI-RA	Conventional imaging smoke beam smoke detector including reflector - ULC approved
OSP-002	Laser Alignment tool
OSP-004	Test filter - 10 pack
RTS151KEY	Test and reset station for flush mount
RTS151KIT	Test and reset station for surface mount
BEAMHKR	Heater kit for the reflector
6500MMK	Multi-mount accessory for ceiling or wall mounting with additional mounting adjustment

Specifications

Operating Voltage Range

10.2 to 32 VDC (12 or 24 VDC nominal)

Maximum Standby Current

@32 VDC	7mA
@24 VDC	11mA
@12 VDC	20mA
@10.2 VDC	50mA

Maximum Alarm Current (LED on)

@32 VDC	11mA
@24 VDC	15mA
@12 VDC	24mA
@10.2 VDC	54mA

Environmental Specifications

Application Temperature Range

-4 °F to 131 °F (-20 °C to +55 °C)

Product UL listed for use from 32 °F to 100 °F (0 °C to 37.8 °C)

Humidity

0 to 95% Relative Humidity (non- condensing)

IP Rating

IP55

Mechanical Information

Weight OSI-R:

2.48 lbs (1.12 kg)

Shipping weight OSI-R:

3.91 lbs (1.77 kg)

Wire Gauge for Terminals

14 AWG (2.08 mm²)

Colour:

Lyric White

Detector (WxHxD)

10" x 6" x 4.5"

(254 mm x 152.4 mm x 114.3 mm)

Reflector

7.87" x 9.06" (200 mm x 230 mm)

www.xtralis.com

UK and Europe +44 1442 242 330 **The Americas** +1 800 229 4434

Middle East +962 6 588 5622 **Asia** +86 21 5240 0077 **Australia and New Zealand** +61 3 9936 7000

The contents of this document are provided on an "as is" basis. No representation or warranty (either express or implied) is made as to the completeness, accuracy or reliability of the contents of this document. The manufacturer reserves the right to change designs or specifications without obligation and without further notice. Except as otherwise provided, all warranties, express or implied, including without limitation any implied warranties of merchantability and fitness for a particular purpose are expressly excluded.

Xtralis, the Xtralis logo, The Sooner You Know, VESDA-E, VESDA, ICAM, ECO, OSID, HeiTel, ADPRO, IntrusionTrace, LoiterTrace, ClientTrace, SmokeTrace, XCa, XOn, iTrace, iCommand, iRespond, iCommission, iPIR, and FMST are trademarks and/or registered trademarks of Xtralis and/or its subsidiaries in the United States and/or other countries. Other brand names mentioned herein are for identification purposes only and may be trademarks of their respective holder(s). Your use of this document does not constitute or create a licence or any other right to use the name and/or trademark and/or label.

This document is subject to copyright owned by Xtralis. You agree not to copy, communicate to the public, adapt, distribute, transfer, sell, modify or publish any contents of this document without the express prior written consent of Xtralis.

Doc. no. 35070_00

Part No. 30994

